

Product Specification

Engineering Brick

Cat 30 Engineered Brick in a Smooth Finish



Barleystone Engineering Brick Cat 30 are specially produced and manufactured using advanced manufacturing processes in a controlled environment. Our Engineering brick is designed for use in engineering and utility environments that require a higher strength brick with high durability, up to a compressive strength of 30N.

Barleystone Engineering Bricks are manufactured to ensure compliance to BS EN 771-3 : 2011

Product Data

Product	Strength N/mm ²	Dimensions (mm)	No. Per Bale	Bale Weight Kg
Engineered Brick	30	215 x 100 x 63	480	1425

Technical Data

Product Type	Concrete Engineered Brick
Manufactured to	BS EN 771-3:2011
Brick Type	Engineering (Cat 30)
Compressive Strength	>30N/mm ²
Shrinkage (Moisture)	0.44mm/m
Unit Weight	2.9 kg per brick (avg)
Tolerance	Cat D1
Water Absorption	5-8%
Net Dry Density	2220 kg/m ³
Gross Dry Density	1900 kg/m ³
Thermal Conductivity	Protected 1.59W/m K exposed 1.70W/m K
Quality Systems	European Standards - Barleystone are BS EN ISO9001-2008 registered
Manufacturing Process	Hydraulically pressed semi-dry concrete
Constituents	Aggregates, sand & cement
Finish	Close Textured - Smooth Finish
Packaging	Baled & Strapped

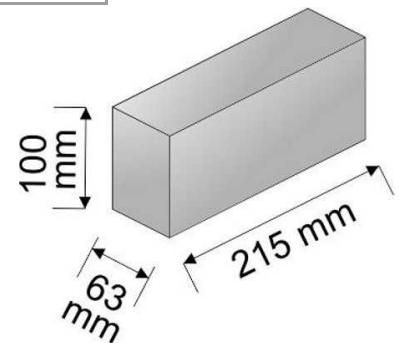

FEATURES & BENEFITS

- ⇒ High Compressive Strength
- ⇒ Low absorption
- ⇒ Can be used for building up manholes
- ⇒ Manufactured in a controlled environment
- ⇒ Very low occurrence of efflorescence
- ⇒ Dimensionally accurate
- ⇒ Low wastage levels
- ⇒ Frost resistant

Disclaimer

No liability can be accepted by Barleystone for errors or omissions on information supplied. As these bricks contain cement they may suffer from temporary efflorescence, this is in no way detrimental to their performance. Barleystone will not accept responsibility for incorrect use of products, the specifier/customer must select the correct products for their chosen application.