

GRANT

Vortex Outdoor Condensing Oil Boilers

USER, INSTALLATION and SERVICING INSTRUCTIONS

Vortex External Modules with outputs up to 240,000 Btu/h

For use with Kerosene only

After installing the boiler leave these instructions with the User

IMPORTANT NOTICE

This appliance must be commissioned upon installation, the information recorded and returned to Grant Engineering (Ireland) Ltd., using the form contained within the boiler passport provided. Failure to do so may invalidate the warranty.



This appliance is deemed a controlled service and specific regional statutory requirements may be applicable.



LIST OF CONTENTS

Section	Subject	Page
1	Introduction	3
2	User instructions	4
3	Boiler technical information	7
4	General boiler information	11
5	Condensate disposal	20
6	Boiler installation	21
7	Commissioning and Boiler passport	31
8	Information for the user	33
9	Boiler servicing	34
10	Wiring diagram	37
11	Fault finding	38
12	Burner heads	40
13	Burner spares	41
14	Health and safety information	43
15	EC declaration of conformity	44

1.1 How a condensing boiler works

During the combustion process, hydrogen and oxygen combine to produce heat and water vapour. The water vapour produced is in the form of superheated steam in the heat exchanger. This superheated steam contains sensible heat (available heat) and latent heat (heat locked up in the flue gas). A conventional boiler cannot recover any of the latent heat and this energy is lost to the atmosphere through the flue.

The Grant Vortex condensing boiler contains an extra heat exchanger which is designed to recover the latent heat normally lost by a conventional boiler. It does this by cooling the flue gases to below 90° C, thus extracting more sensible heat and some of the latent heat. This is achieved by cooling the flue gases to their dew point (approximately 55° C).

To ensure maximum efficiency, the boiler return temperature should be 55° C or less, this will enable the latent heat to be condensed out of the flue gases. The boiler will achieve nett thermal efficiencies of 100%.

To achieve maximum performance from the Grant Vortex boiler, it is recommended that the heating system is designed so that a temperature differential of 20° C between the flow and return is maintained. The use of modulating circulating pumps (now widely available) and effective control systems should be considered.

The Grant Vortex boiler will however still operate at extremely high efficiencies even when it is not in condensing mode and therefore is suitable for fitting to an existing heating system without alteration to the radiator sizes. The boiler is capable of a maximum flow temperature of 75° C.

1.2 Heating system design considerations

To achieve the maximum efficiencies possible from the Grant Vortex boiler, the heating system should be designed to the following parameters:

Radiators:-

Flow temperature	70° C
Return temperature	50° C
Differential	20° C

Underfloor:-

Flow temperature	50° C
Return temperature	40° C
Differential	10° C

- 1 Size radiators with a mean water temperature of 60° C.
- 2 Design system controls with programmable room thermostats or use weather compensating controls to maintain return temperatures below 55° C.

The boiler should not be allowed to operate with return temperatures of less than 40° C when the system is up to operating temperature.

- 3 The use of a pipe stat is recommended to control the return temperature when using weather compensating controls.

2 - USER INSTRUCTIONS

2.1 About your boiler

The boiler is fully automatic once switched on, providing central heating (and also heating your domestic hot water if you have an hot water cylinder fitted).

An illuminated On/Off switch, see Fig. A, is fitted to the External modules, which lights when the boiler is switched on, but does not necessarily indicate the burner is firing.

2.2 Boiler controls (see Fig. A)

To access the External module controls, remove the front panel by turning the handle and withdrawing it forwards at the bottom.

2.3 Lighting your boiler (see Fig. A)

- 1 Ensure that** - There is sufficient fuel, of the correct type, in the supply tank and all fuel supply valves are open. The water supply is on. The electricity supply to the boiler is off. The Boiler On/Off switch is set to off (the neon in the switch is not alight). The Test switch is set to Off. The room thermostat (if fitted) is at the desired setting. The boiler thermostat is set to the required setting.
- 2 Switch on the electricity supply to the boiler.
- 3 Set the Boiler On/Off switch to on. A neon in the switch lights when it is in the on position.

The boiler will now light automatically.

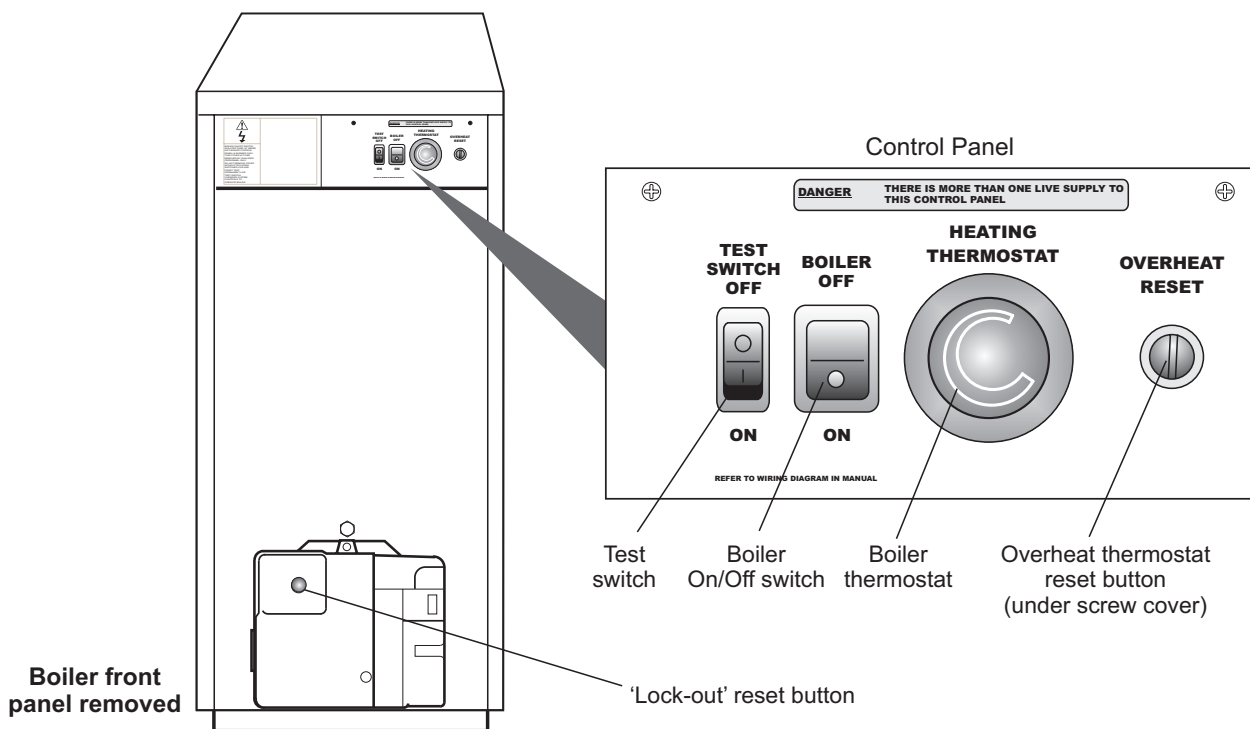

Controls for External modules - Fig. A

2.4 Turning off your boiler (see Fig. A)

For short periods - Set the boiler switch to OFF. To restart, set the switch to ON.

For long periods - Set the boiler switch to OFF. If required, the fuel supply valve may be closed and the water and electricity supplies turned off at the mains.

Note: If the electricity, fuel and water supplies are turned off, the built-in frost thermostat will **not** operate.

2.5 Points to check if burner fails to light

- 1 Check that the boiler switch is ON.
- 2 Check that any remote programmer (if fitted) is working and is in an 'on' period.
- 3 Check that all thermostats are set to the desired setting and are calling for heat.
- 4 Check if the burner 'Lock-out' reset button (on the burner) is lit. If it is, press it to start the burner. If the burner fails to light and goes to 'Lock-out' again, check that you have sufficient fuel in the storage tank and that the fuel supply valve is open. Check that the fire valve in the oil supply line has not tripped.
- 5 Ensure that a fuse has not blown or that the electricity supply has not failed.
- 6 Check to see if the safety thermostat has operated (see Section 2.7).

If the burner still fails to light after carrying out these checks then a fault exists. Switch off the electricity supply to the boiler and contact your Service engineer.

2.6 About your fuel

Grant Vortex External modules operate on Class C2 Kerosene only. You should always quote this type of fuel when ordering from your supplier.

Do not wait until the fuel runs out before you order some more. Sludge in the bottom of the tank may be drawn into the fuel lines. If it is possible, switch off the boiler when the new supply is delivered and leave the fuel to settle for an hour before restarting the boiler.

2.7 General notes and care of your system

- 1 **Boiler thermostat** - This control allows the temperature of the water leaving the boiler to heat the radiators and domestic hot water to be adjusted.

Note: If you have a cylinder thermostat on your hot water cylinder, this will control the temperature of your domestic hot water. The boiler thermostat setting must be equal to or above the cylinder thermostat setting to enable the cylinder thermostat to control the domestic hot water system.

- 2 **Burner Lock-out reset button** - If there is a burner malfunction, a built-in safety circuit switches the burner off and the 'Lock-out' reset button (on the burner) will light. Usually such malfunctions are short lived and pressing the reset button will restore normal operation.

If the burner continually goes to 'Lock-out' a fault exists **or** the fuel supply is low. If you have sufficient fuel, you will need to call your Service engineer.

- 3 **Safety thermostat** - Your boiler is fitted with a safety overheat thermostat which will automatically switch off the boiler in the case of a control malfunction causing overheating.

If your boiler goes off and you try to light it but nothing happens and the 'Lock-out' reset button on the burner is not lit, the overheat thermostat has probably operated. The boiler will not light until the thermostat is reset. To reset, unscrew the small plastic cap (see Fig. A), press the button then replace the cap.

If this condition continually repeats, contact your Service engineer.

- 4 **Ventilation** - Always ensure that the boiler has adequate ventilation. Any ventilation openings **must not** be obstructed. Periodically check that they are clear.

Do not attempt to 'box in' the boiler or build a compartment around.

Do not place any combustible material around or on the boiler or flue pipe.

Do not place anything against the door of the External modules that might obstruct the ventilation openings.

- 5 **Flue terminal** - The flue terminal **must not** be obstructed or damaged.

In severe conditions check that the terminal does not become blocked by snow.

2 - USER INSTRUCTIONS

- 6 Frost protection** - Your Installer may have fitted a frost thermostat. If not, and you are likely to be away for a short time, leave the boiler on with the boiler thermostat set at a low setting. For longer periods the boiler and system should be drained. Contact your Service engineer for draining and filling the system.

The control panel of the External modules includes a built-in frost thermostat factory set to 5°C.

Note: For Vortex External modules we recommend that a combined antifreeze and corrosion inhibitor be used in the primary water system.

- 7 Cleaning and servicing** - Lightly wipe over the case with a damp cloth and a little detergent. **Do not** use abrasive pads or cleaners.

You must have your boiler serviced at least once a year to ensure safe and efficient operation. Contact your Service engineer for further details.

Warning note - External equipment operated at 230 volts should not be serviced or repaired under adverse weather conditions.

- 8 Failure of electricity supply** - If the electricity supply fails, the boiler will not operate. It should relight automatically when the supply is restored.

2.8 Electricity supply

The boiler requires a 230/240 V ~ 50 Hz supply. It must be protected by a 5 Amp fuse.

Warning: This appliance must be earthed.

2.9 Sealed central heating system

If your boiler is operating on a sealed heating system, the installer will have pressurised the system and should have told you (or set it on the pressure gauge) the system pressure when cold (this is normally between 0.5 and 1.0 bar, which will increase slightly when hot). If the pressure (when cold) is below the set pressure mentioned above, you can re-pressurise the system. If the system requires frequent re-pressurising, ask your Installer or Service engineer to check the heating system for leaks and to check the expansion vessel air charge.

An automatic filling system should not be used on a sealed central heating system.

The boiler or system will be fitted with an automatic air vent to remove air from the system. Any air trapped in the radiators should be removed by venting the radiators using the vent screw at the top of each radiator. Only vent a radiator if the top is cool and the bottom is hot. Excessive venting will reduce the system pressure, so only vent when necessary and check the system pressure as mentioned above. Re-pressurise the system if necessary.

The boiler or system may be fitted with a safety valve to release excess pressure from the system. If water or steam is emitted from the end of the safety valve discharge pipe, switch off the boiler and contact your Installer or Service engineer.

The expansion vessel air charge must be checked annually. Failure to maintain an adequate air charge in the vessel may invalidate the warranty.

To re-pressurise the system by adding water:

- 1 Only add water to the system when it is cold and the boiler is off. **Do not overflow.**
- 2 Ensure the flexible filling loop (see Fig. B) is connected and that the shut off valve connecting it to the boiler is open and the double check valve at the front is closed.
A valve is open when the operating lever is in line with the valve, and closed when it is at right angles to it.
- 3 Gradually open the double check valve on the front of the filling loop until water is heard to flow.
- 4 Vent each radiator in turn, starting with the lowest one in the system, to remove air.
- 5 Continue to fill the system until the pressure gauge indicates between 0.5 and 1.0 bar. Close the fill point valve.
- 6 Repeat steps 4 and 5 as required.
- 7 Close the valves either side of the filling loop and disconnect the loop.

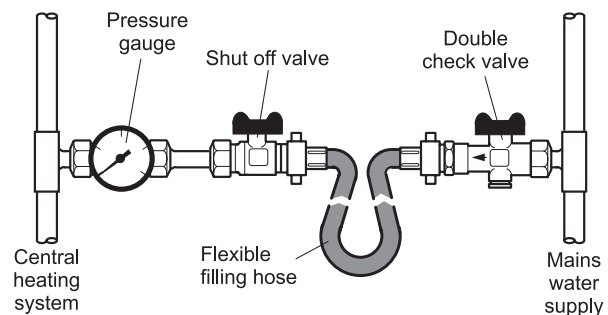

Sealed system filling loop arrangement - Fig. B

3 - BOILER TECHNICAL INFORMATION

3.1 Boiler technical data

Model		Vortex External Module					
		50/70	50/90	90/120	120/155	155/200	200/240
Water content	litre	16.5	19	21	21	50	50
	gal	3.6	4.2	4.7	4.7	11	11
* Weight (dry)	kg	99	157	174	174	335	339
Max. heat output (kerosene)	kW	21	26	36	46	58	70
	Btu/h	71,650	88,700	122,840	157,000	197,876	238,840
Flow connection		22 mm	22 mm	28 mm	28 mm	1¼" BSP	1¼" BSP
Return connection		22 mm	22 mm	28 mm	28 mm	1¼" BSP	1¼" BSP
Condensate connection		21.5 mm plastic overflow pipe					
Waterside resistance							
Flow/Return temp. diff. of 10°C		28.5 mbar	28.5 mbar	26.0 mbar	26.0 mbar	26.0 mbar	26.0 mbar
Flow/Return temp. diff. of 20°C		10.0 mbar	10.0 mbar	9.5 mbar	9.5 mbar	9.5 mbar	9.5 mbar
Maximum static head		28 m					
Minimum circulating head		1m					
Boiler thermostat range		65 to 75°C					
Limit (safety) stat shut off temp		111°C ± 3°C					
Max. hearth temperature		Less than 50°C					
Electricity supply		230/240 V ~ 50 Hz Fused at 5 Amp					
Motor power		90 W max.				150 W max.	150 W max.
Starting current		4.2 Amp	2.6 Amp	2.6 Amp	4.2 Amp	6.4 Amp	6.4 Amp
Running current		0.85 Amp					
Oil connection		¼" BSP Male (on end of flexible fuel hose)					
Max operating press - sealed sys		2.5 bar					
Max operating press - open sys		2.5 bar					

* Weight includes burner but excludes flue.

3 - BOILER TECHNICAL INFORMATION

3.2 Sealed system data - none available for 155/200, 200/240

Model	50/70	50/90	90/120 and 120/155
Heating system pressure (cold)	Maximum 1.0 bar, Minimum 0.5 bar		
Operating pressure of pressure relief valve	2.5 bar		
Expansion vessel size (approximately)	10 litres	12 litres	16 litres
Max heating system volume (including boiler)	106 litres	128 litres	170 litres
Cold water mains connection	15 mm copper pipe		
Pressure relief valve discharge connection	15 mm copper pipe		
Circulating pump head	6 m	6 m	7 m

3.3 Grant Vortex External modules using Class C2 kerosene

Note: Grant Vortex External modules are only for use with kerosene.

Model and burner type	Heat Output		HARP/SEDBUK efficiency (%)	Nozzle	Oil press. (bar)	Smoke No.	Burner head type	Burner head setting	Air disc position	Fuel flow rate (kg/h)	Flue gas temp. (°C)	CO ₂ (%)
	(kW)	(Btu/h)										
50/70 Riello RDB2.2	15.0	51,200	93	0.50/80°EH	7.0	0 - 1	T1	Fixed	B	1.29	66	12.0
	18.3	62,400		0.55/80°EH	7.5	0 - 1	T1	Fixed	C	1.56	73	12.0
	* 21.0	71,650		0.60/80°EH	9.0	0 - 1	T1	Fixed	C	1.83	80	12.0
50/90 Riello RDB1	15.0	51,200	94 - 95	0.50/80°EH	7.0	0 - 1	T1	Fixed	-	1.25	60 - 65	12.0
	20.0	68,240		0.60/80°EH	8.0	0 - 1	T1	Fixed	-	1.67	65 - 70	12.0
	* 23.0	78,500		0.65/80°EH	8.5	0 - 1	T2	Fixed	-	1.94	70 - 75	12.0
	26.0	88,700		0.75/80°EH	8.0	0 - 1	T2	Fixed	-	2.18	68	12.0
90/120 Riello RDB2	26.0	88,700	97	0.75/80°EH	8.0	0 - 1	T3	Fixed	-	2.18	68	12.0
	* 31.5	107,500		0.85/80°EH	9.0	0 - 1	T3	Fixed	-	2.57	70	12.0
	36.0	123,000		1.00/80°EH	9.1	0 - 1	T3	Fixed	-	3.01	78	12.0
120/155 Riello RDB2.2	36.0	123,000	92.62	1.00/80°EH	9.0	0 - 1	T3	Fixed	-	3.01	78	12.0
	* 41.5	141,600		1.20/80°S	8.0	0 - 1	T5	Fixed	-	3.56	80	12.0
	46.0	157,000		1.25/80°S	8.0	0 - 1	T5	Fixed	-	3.90	88	12.0
155/200 Riello RDB3.2	46.0	156,952	94.1	1.25/80°S	8.0	0 - 1	GIB	0	-	4.01	75 - 80	12.0
	* 52.0	177,424		1.35/80°S	9.5	0 - 1	GIB	0	-	4.47	75 - 80	12.0
	58.0	197,896		1.65/80°S	8.0	0 - 1	GIB	0	-	5.05	75 - 80	12.0
200/240 Riello RDB3.2	58.0	197,896	93.6	1.65/80°S	8.0	0 - 1	GIB	0	-	5.05	75 - 80	12.0
	* 64.0	218,368		1.65/80°S	9.5	0 - 1	GIB	0	-	5.58	75 - 80	12.0
	70.0	238,840		1.75/80°S	9.5	0 - 1	GIB	4	-	6.01	75 - 80	12.0

Notes:

- 1 The data given above is approximate only.
- 2 The above settings may have to be adjusted on site for the correct operation of the burner.
- 3 Gas Oil is **not** suitable for use with the Grant Vortex boiler range.
- 4 The net flue gas temperatures given above are ± 10%.
- 5 When commissioning the air damper **must** be adjusted to obtain the correct CO₂ level.
- 6 * Factory settings.
- 7 The combustion door test point may be used for CO₂ and smoke readings only. Do not use this test point for temperature or efficiency readings.
- 8 When setting the 50/90 to 51,200 or 68,240 Btu/h output or the 120/155 to 123,000 Btu/h output the combustion head must be changed. Refer to Section 7 Commissioning.
When setting the 50/70 to 51,200 Btu/h output the burner air adjuster disc requires repositioning. Refer to Section 9.4 Cleaning the burner.
- 9 The installer **must** amend the boiler data label if the output is changed.

Flue gas analysis

To allow the boiler to be commissioned and serviced, the boiler is supplied with a combustion test point on the front cleaning door. When this test point is used please note the following:

1. The test point is for CO₂ and smoke readings only.
2. The boiler efficiency and temperature must be taken from the flue test point on high level and vertical flue adaptors.
3. Low level flues do not contain a test point. The temperature and efficiency readings must be taken from the flue terminal.

3 - BOILER TECHNICAL INFORMATION

3.4 Boiler dimensions

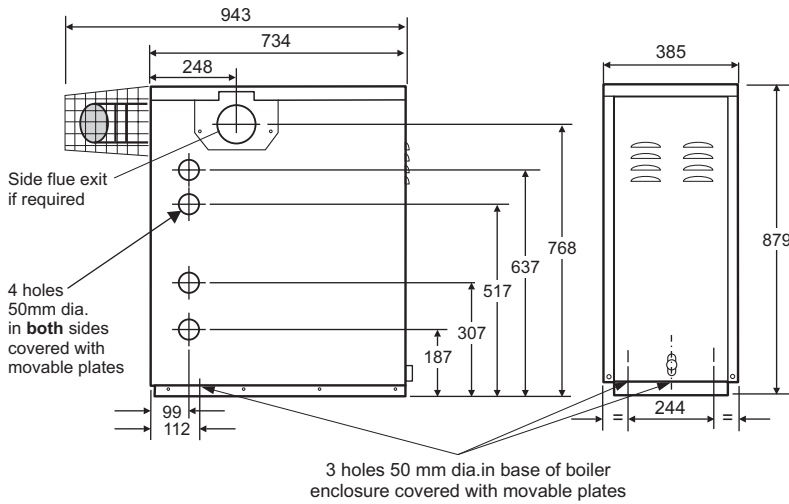

Fig 1a - 50/70 dimensions

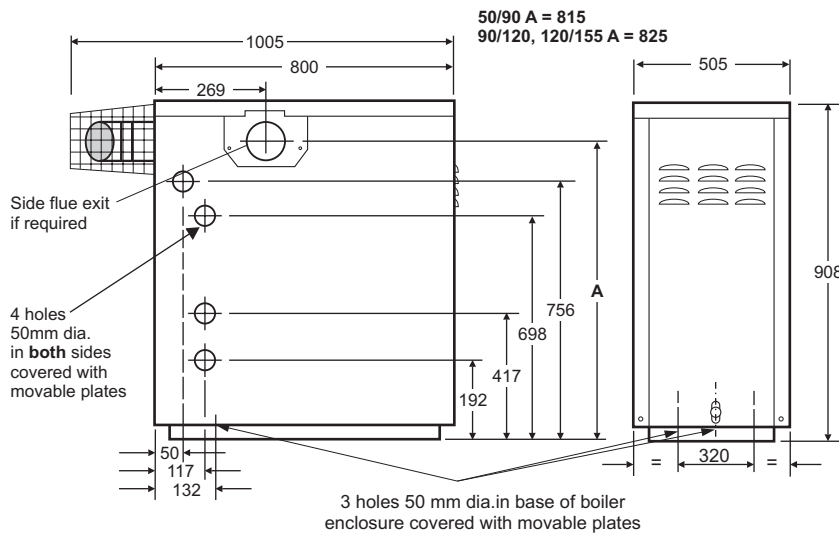

Fig 1b - 50/90, 90/120 and 120/155 dimensions

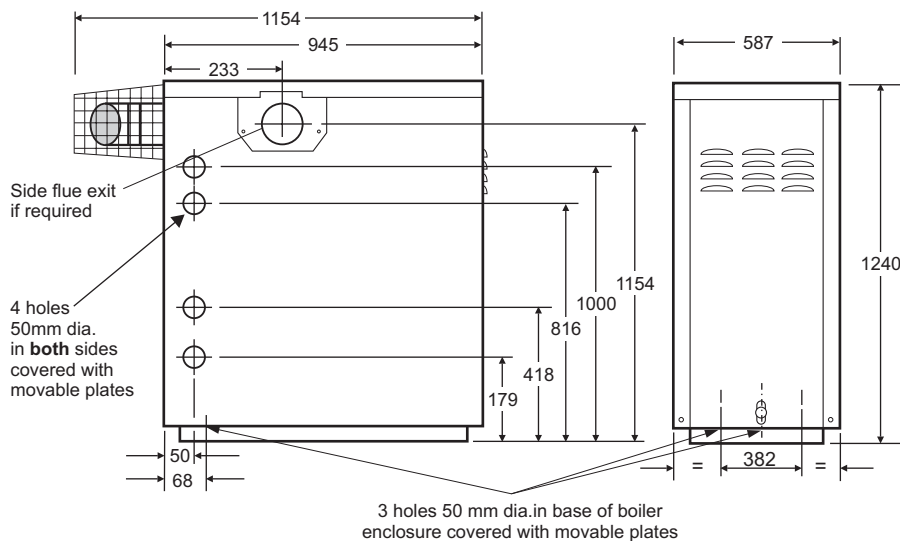

Fig 1c - 155/200 and 200/240 dimensions

4 - GENERAL BOILER INFORMATION

4.1 Boiler description

Grant Vortex External Modules have an insulated weatherproof enclosure made of galvanised steel, and are designed for external installation, either against a wall or free standing some distance away from the property, as required. For flue clearances see page 15.

The Vortex External modules are part of the Grant range of automatic pressure jet oil boilers have been designed for use with a fully pumped central heating system with indirect domestic hot water cylinder. They are not suitable for use with either a direct cylinder or a 'primatic' cylinder or gravity hot water..

The boilers are suitable for use on open vented or sealed central heating systems.

All models are supplied with the control panel and burner factory fitted.

The factory fitted low level discharge flue system can be adjusted on site for either rear, left hand or right hand flue outlet position, as required.

An external Plume Diverter kit (Fig. 16) is also available from your local stockist. Refer to Section 6.4 for further details.

4.2 Boiler components

All burners are pre-set for use with kerosene and are supplied ready to connect to a single pipe fuel supply system with a loose flexible fuel line and $\frac{3}{8}$ " to $\frac{1}{4}$ " BSP male adaptor supplied with the boiler.

If required, an additional flexible fuel line (600 mm) and $\frac{3}{8}$ " to $\frac{1}{4}$ " BSP male adaptor are available to purchase from your local stockist, for two-pipe oil supply systems.

The temperature of the water leaving the boiler to heat the radiators and hot water cylinder is User adjustable.

The boiler is fitted with an overheat thermostat (which allows it to be used on a sealed central heating system) which will automatically switch off the boiler if the heat exchanger exceeds a pre-set temperature of $111^{\circ}\text{C} \pm 3^{\circ}\text{C}$.

The control panel is fitted with an ON/OFF switch, boiler thermostat control knob and the manual reset button for the overheat thermostat

4.3 Regulations to comply with

Installation of a Grant Vortex boiler must be in accordance with the following recommendations:-

- a Local Building Regulations, and Building Standards issued by the Department of the Environment and any local Byelaws etc.
- b Model and local Water Undertaking Byelaws.
- c Applicable Control of Pollution Regulations.
- d The following OFTEC requirements:-
 - OFST 100 Polythene oil storage tanks for distillate fuels.
 - OFST 200 Fuel oil storage tanks and tank bunds for use with distillate fuels, lubrication oils and waste oils.

Further information may be obtained from the OFTEC Technical Information Book 3 (Installation requirements for oil fired boilers and oil storage tanks).

The installation should also be in accordance with the latest edition of the following British Standard Codes of Practice:-

- | | |
|-----------|--|
| BS 715 | Metal flue pipes, fittings, terminals and accessories. |
| BS 799:5 | Oil storage tanks. |
| BS 1181 | Clay flue linings and flue terminals. |
| BS 4543:3 | Factory made insulated chimneys for oil fired appliances. |
| BS 4876 | Performance requirements for oil burning appliances. |
| BS 5410:1 | Code of Practice for oil firing appliances. |
| BS 5449 | Forced circulation hot water systems. |
| BS 7593 | Code of Practice for treatment of water in heating systems. |
| BS 7671 | Requirements for electrical installations, IEE Wiring Regulations. |

Failure to install and commission appliances correctly may invalidate the boiler warranty.

IMPORTANT

Before starting any work on the boiler, or fuel supply please read the health and safety information given in Section 14 on page 43.

4 - GENERAL BOILER INFORMATION

**Regional statutory requirements may deem this appliance to be a 'controlled service'.
Where this is the case, it is a legal requirement that the appliance is installed and commissioned either under the remit of building control or by a 'Competent person' such as a suitably qualified Oftec registered technician.**

4.4 Fuel supply

4.4.1 Fuel storage

The tank should be positioned in accordance with the recommendations given in BS 5410:1:1997, which gives details of filling, maintenance and protection from fire.

A steel tank may be used and must be constructed to BS 799:5:1987 and OFST 200.

A galvanised tank must not be used.

A plastic tank may be used and must comply with OFST 100.

Note: Plastic tanks should be adequately and uniformly supported on a smooth level surface, across their entire base area.

4.4.2 Fuel pipes

- 1 Fuel supply pipes should be of copper tubing with an external diameter of at least 10 mm.
Galvanised pipe must not be used.
All pipe connections should preferably use flared fittings. Soldered connections **must not** be used on oil pipes.
- 2 Flexible hoses must not be used outside the boiler case.
- 3 A remote sensing fire valve (not a fusible head type) must be installed in the fuel supply line, with the sensing head located above the burner. Recommendations are given in BS 5410:1:1997.

- 4 A metal bowl type filter with a replaceable micronic filter must be fitted in the fuel supply line adjacent to the boiler. A shut-off valve should be fitted before the filter, to allow the filter to be serviced.
- 5 A flexible fuel hose, adaptor and $\frac{1}{4}$ " BSP isolation valve are supplied loose with the boiler for the final connection to the burner. If a two pipe system or 'Tiger Loop' type de-aerator is used, an additional flexible fuel hose (600 mm) and $\frac{3}{8}$ " to $\frac{1}{4}$ " BSP male adaptor are available to purchase from your local stockist. If a 'Tiger Loop' is fitted it should not be fitted indoors or within a boiler casing.
- 6 Metal braided flexible hoses should be replaced annually when the boiler is serviced. Long life flexible hoses should be inspected annually and replaced at least every 60 months.

4.4.3 Single pipe system - (See Fig. 2)

- 1 Where the storage tank outlet is above the burner the single pipe system should be used. The height of the tank above the burner limits the length of pipe run from the tank to the burner.
- 2 As supplied the burner is suitable for a single pipe system.

Head A (m)	Maximum pipe run (m)	
	10 mm OD pipe	12 mm OD pipe
0.5	10	20
1.0	20	40
1.5	40	80
2.0	60	100

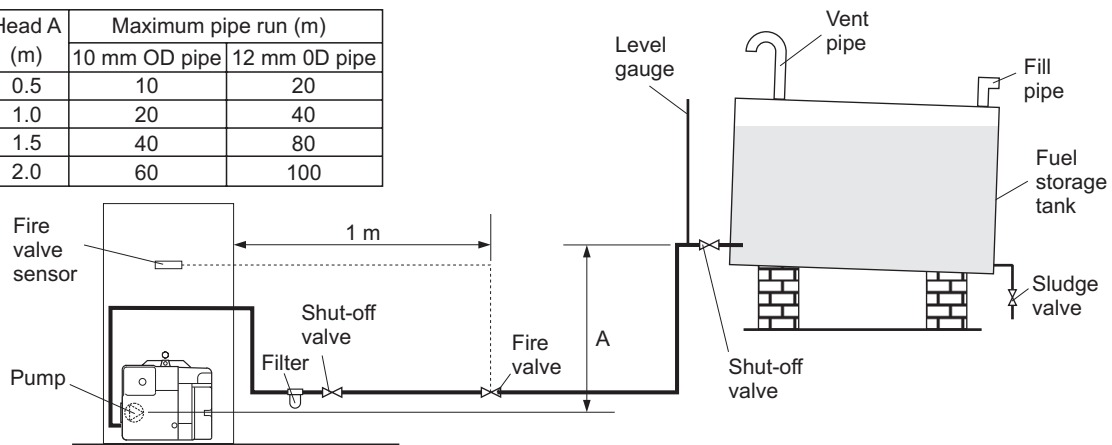

Fig. 2 - Single pipe system

4 - GENERAL BOILER INFORMATION

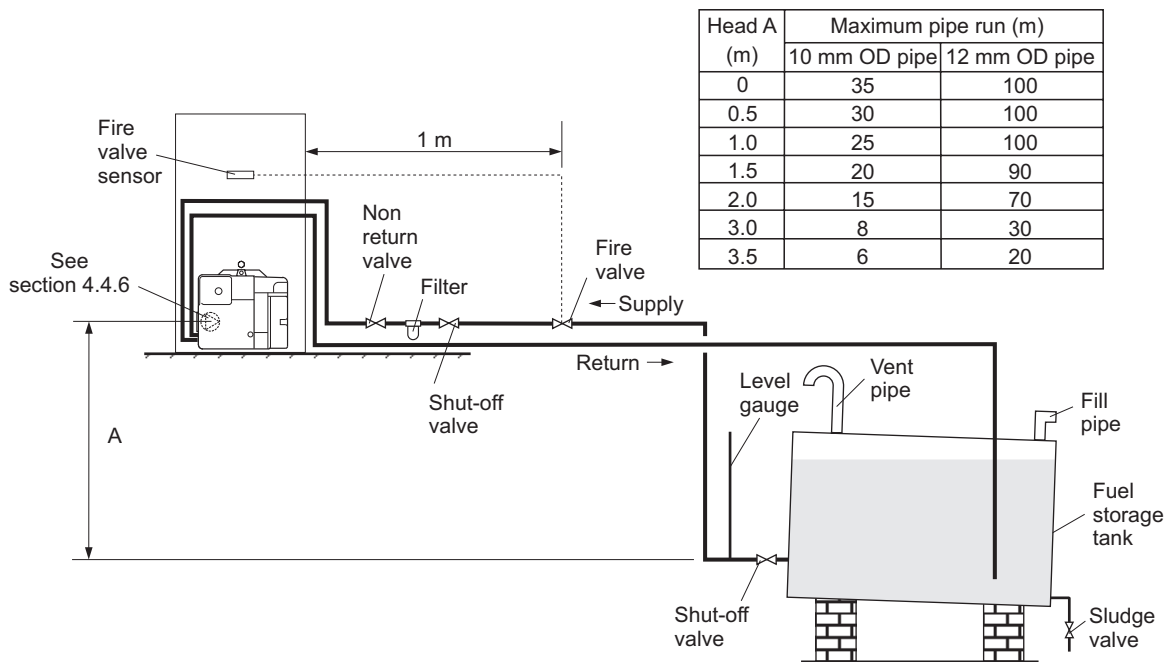

Fig. 3 - Two pipe system

4.4.4 Two pipe system - (See Fig. 3)

- 1 When the storage tank outlet is below the burner, the two pipe system should be used. The pipe runs should be as shown in Fig. 3. The return pipe should be at the same level in the tank as the supply pipe, both being 75 to 100 mm above the base of the tank. The pipe ends should be a sufficient distance apart so as to prevent any sediment disturbed by the return entering the supply pipe.
- 2 Avoid the bottom of the tank being more than 3 m below the burner.
- 3 A non-return valve should be fitted in the supply pipe together with the filter and fire valve. A non-return valve should be fitted in the return pipe if the top of the tank is above the burner.
- 4 To be used with a two-pipe system, the burner **must** be fitted with an additional flexible fuel hose (a flexible fuel hose (600 mm) and $\frac{3}{8}$ " to $\frac{1}{4}$ " BSP male adaptor are available to purchase from your local stockist.
- 5 The pump vacuum should not exceed 0.4 bar. Beyond this limit gas is released from the oil.

For guidance on installation of top outlet fuel tanks and suction oil supply sizing, see OFTEC booklet T1/139. Available at www.oftec.org.uk

4.4.5 Tiger Loop system - (See Figs. 4 and 5)

- 1 When the storage tank is below the burner, an alternative to a two pipe system can be achieved using the 'Tiger Loop' type oil de-aerator. This effectively removes the air from the oil supply on a single pipe lift.
- 2 The de-aerator is connected close to the boiler as a two pipe system (omitting the non-return valve) as shown in Fig. 4. Refer to the manufacturers instructions supplied with the de-aerator. The de-aerator **must** be mounted vertically and externally.
- 3 To be used with a de-aerator, the burner **must** be fitted with an additional flexible fuel hose (a flexible fuel hose (600 mm) and $\frac{3}{8}$ " to $\frac{1}{4}$ " BSP male adaptor are available to purchase from your local stockist. See Section 4.4.6.

4 - GENERAL BOILER INFORMATION

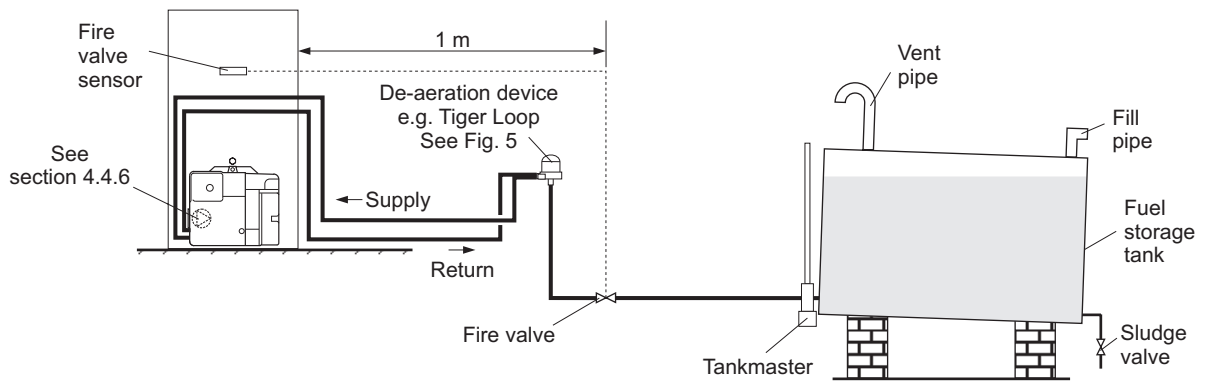

Fig. 4 - De-aeration device system

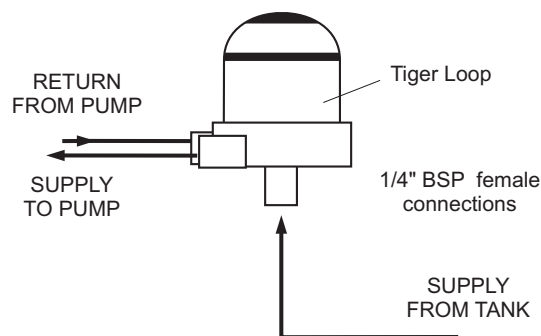

Fig. 5 - Tiger loop 'de-aeration' device

4.4.6 Two pipe oil supplies

Riello RDB burner - See Fig. 6

- 1 The fuel pump is supplied for use with a single pipe fuel supply system. For use on a two pipe system, it is necessary to fit the By-pass screw (see Fig. 6) into the tapping in the return port.
- 2 The By-pass screw is supplied in the boiler accessory pack.
- 3 Remove the plastic burner cover (two screws).
- 4 Remove and discard the blanking plug from the return connection of the pump and fit the By-pass screw using an hexagonal key.
- 5 Connect the return oil flexible fuel hose to the pump.
- 6 Connect the $\frac{3}{8}$ " to $\frac{1}{4}$ " BSP adaptor to the flexible fuel hose.

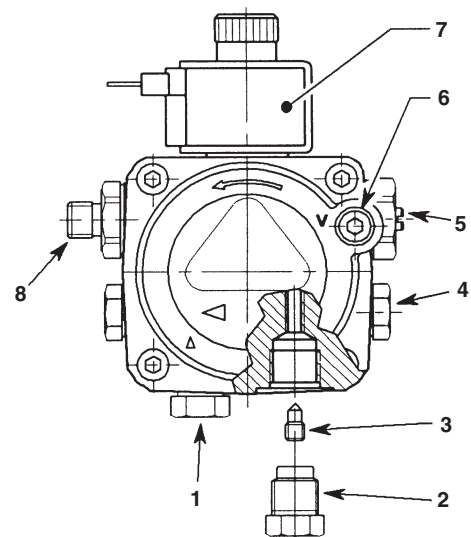

Fig. 6 - Riello RDB pump

- 1 Oil inlet connection
- 2 Return connection
- 3 By-pass screw
- 4 Pressure gauge connection
- 5 Pressure adjuster
- 6 Vacuum gauge connection
- 7 Solenoid
- 8 Supply to nozzle

4 - GENERAL BOILER INFORMATION

4.5 Electricity supply

- 1 A 230/240 V ~ 50 Hz mains supply is required.

The boiler must be earthed.

- 2 The supply must be fused at 5 Amp and there must only be one common isolator for the boiler and control system, providing complete electrical isolation.
- 3 A fused double pole switch or a fused three pin plug and shuttered outlet socket should be used for the connection.
- 4 The power supply cable should be at least 0.75 mm² PVC as specified in BS 6500, Table 16.
- 5 All the wiring and supplementary earth bonding external to the boiler must be in accordance with the current I.E.E. Wiring Regulations.
- 6 Any room thermostat or frost thermostat used must be suitable for use on mains voltage.
- 7 The boiler requires a permanent mains supply, do not interrupt it with any external time control.
- 8 In the event of an electrical fault after installation of the boiler, the following electrical system checks must be carried out:- Short circuit, Polarity, Earth continuity and Resistance to earth.

4.6 Frost protection

- 1 External Modules are supplied with a factory fitted frost protection thermostat, located inside the boiler control panel. This is pre-wired to the boiler electrical system and factory set to 5°C.
- 2 For total system protection against freezing, particularly during extended periods without electrical power, Grant recommend the use of a combined heating system antifreeze and corrosion inhibitor, used in accordance with the manufacturer's instructions.

4.7 Boiler location

- 1 The External Module must stand on a solid, level surface capable of supporting the weight of the boiler when full of water, e.g. a prepared concrete standing, paving slabs bedded down on sand/cement, or similar.
- 2 The Module can be installed either against the building or 'free standing' some distance away from the building.
- 3 The Module must be positioned such that the required clearances from the low level flue outlet, as shown in Fig. 7, are achieved.
- 4 Adequate clearance must be left around the Module for servicing. In particular, a minimum clearance of 600 mm above the Module for removal of the top panel and 600 mm at the opposite end to the flue outlet for access to the burner.

Sufficient clearance is required at the rear of the boiler to allow the rear panel to be removed for access to the condensate trap.

- 5 The flue terminal must be a minimum distance of 1.8 m from an oil storage tank.

The flue terminal should be positioned so as to avoid products of combustion accumulating in stagnant pockets around the building or entering into buildings.

4 - GENERAL BOILER INFORMATION

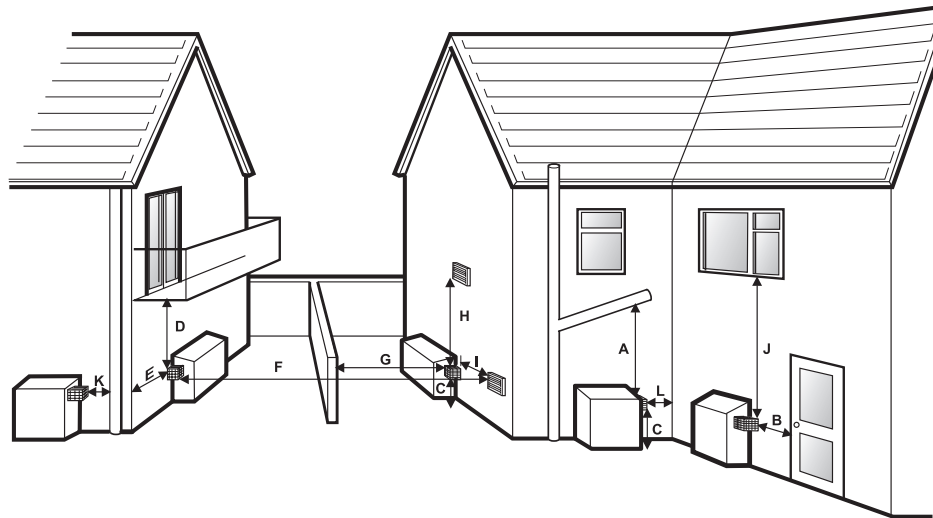

Fig. 7 - Clearances for flue terminals

Terminal position	Min. distance
A Below gutters, eaves or balconies (with protection)	*600
B Horizontally from a door, window or air vent	600
C Above ground, flat roof or balcony level	300
D Below gutters, eaves or balconies (without protection)	*600
E From an external corner	300
F From a terminal facing the terminal	1200
G From a surface facing the terminal	600
H Vertically from a terminal on the same wall	1500
I Horizontally from a terminal on the same wall	**750
J Directly below an opening, air brick, window, etc.	600
K From a vertical drain pipe or soil pipe	300
L From an internal corner	300

Notes: * 75 mm with protection.

** Only applies if one or both terminals are balanced flues.

Distances measured to rim of terminal.

Clearances recommended by Grant Engineering (IRL) Limited in accordance with Building Standards and Building Regulations.

- Notes:**
- 1 An opening means an openable element, such as an openable window, or a permanent opening such as a permanently open air vent.
 - 2 Notwithstanding the dimensions given, a terminal should be at least 300 mm from combustible material, e.g. a window frame.
 - 3 A way of providing protection of combustible material would be to fit a heat shield at least 750 mm wide.

The terminal should be positioned so as to avoid products of combustion accumulating in stagnant pockets around the building or entering into buildings. Care should also be taken that the plume from the condensed flue gases does not cause a nuisance.

4 - GENERAL BOILER INFORMATION

4.8 Water connections

See Figs. 8, 9, 10 and 11

Boiler model	Flow connection		
	Size	Fitting	Supplied
50/70	22 mm pipe	Compression straight	in fittings kit
50/90	22 mm pipe	Compression elbow	in fittings kit
90/120, 120/155	28 mm pipe	Compression straight	in fittings kit
155/200, 200/240	1¼" BSP	Female socket	fitted

Boiler model	Return connection		
	Size	Fitting	Supplied
50/70	22 mm pipe	Compression	fitted
50/90	22 mm pipe	Compression	fitted
90/120, 120/155	28 mm pipe	Compression	fitted
155/200, 200/240	1¼" BSP	Female socket	fitted

The flow and return pipework can exit the boiler enclosure either through the openings provided in both sides (under the movable cover plates) and through the wall when installed against the building, or down and through the openings provided in the base of the enclosure for 'free standing' installations.

Ensure the flow pipe is vented as its the highest point of the boiler.

To avoid the danger of dirt and foreign matter entering the boiler the complete heating system should be thoroughly flushed out - before the boiler is connected and then again after the system has been heated and is still hot. This is especially important where the boiler is used on an old system.

For optimum performance after installation, this boiler and its associated central heating system must be flushed in accordance with the guidelines given in BS 7593:1992 'Treatment of water in domestic hot water central heating systems'.

This must involve the use of a proprietary cleaner, such as BetzDearborn's Sentinel X300 or X400, or Fernox Restorer. Full instructions are supplied with the products, but for immediate information, please contact BetzDearborn on 0151 4209563 or Fernox on 0179 9550811.

For Long term protection against corrosion and scale, after flushing, it is recommended that an inhibitor such as Betzdearborn's Sentinel X100 or Fernox MB-1 is dosed in accordance with the guidelines given in BS 7593:1992.

Failure to implement the guidelines will invalidate the warranty.

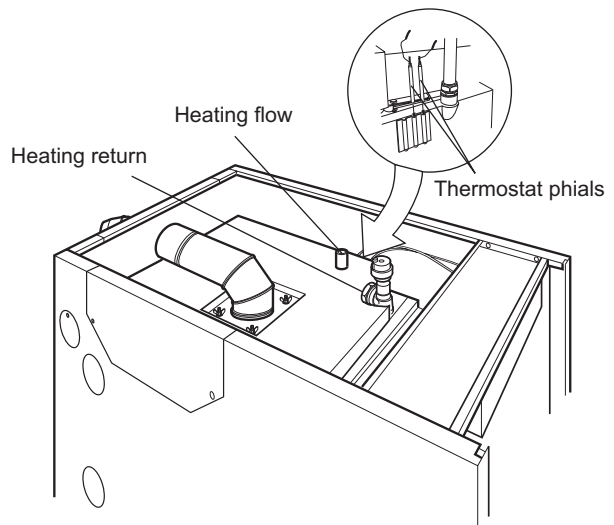

Fig. 8 - 50/90 connections

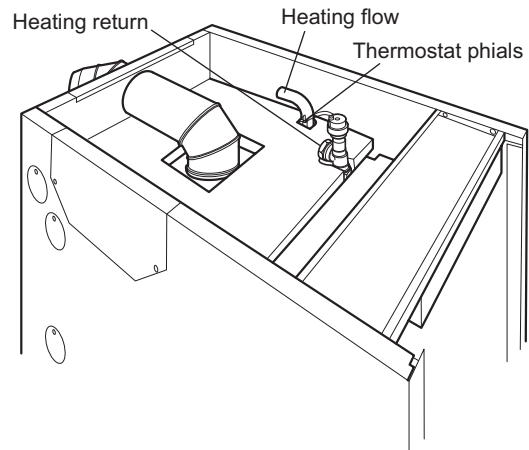

Fig. 9 - 50/70, 90/120, 120/155 connections

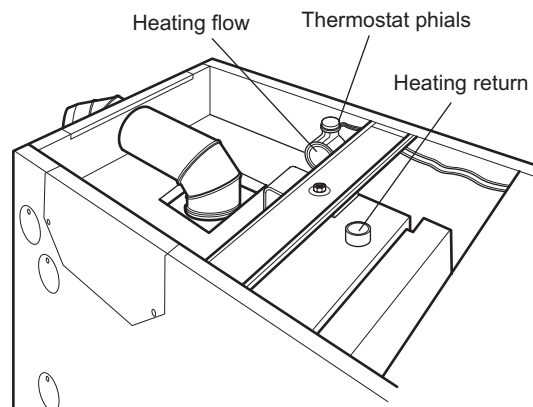

Fig. 10 - 155/200, 200/240 connections

4 - GENERAL BOILER INFORMATION

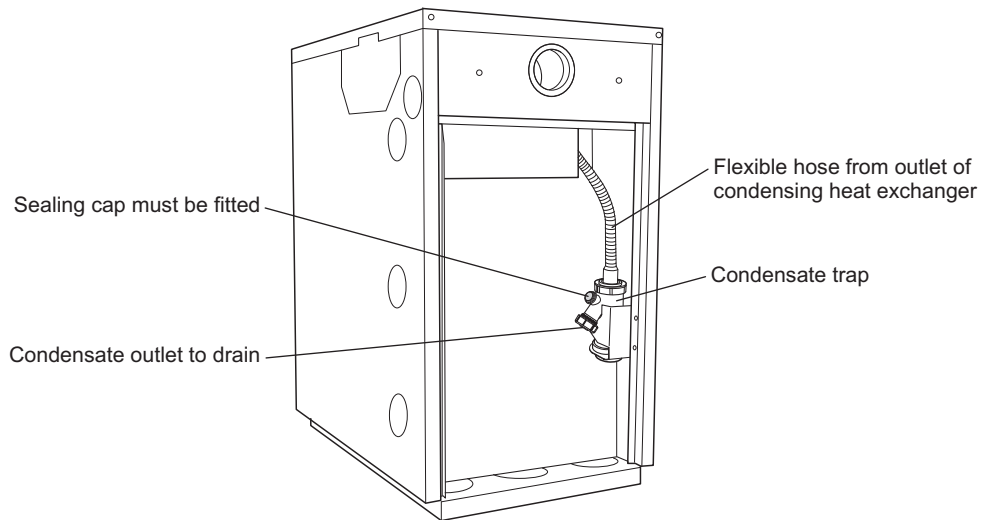

Fig. 11 - All models rear view (panel removed)

4.9 Sealed system kit

See Fig. 12

Grant sealed system kits, incorporating circulating pumps are available. See Section 6.5 and 6.6.

- 1 The boiler is only suitable for use with a sealed system complying with the requirements of BS 5449. The maximum temperature of the central heating water is 75°C.
- 2 The system must be provided with the following items:-
 - a Diaphragm expansion vessel complying with BS 4814.
 - b Pressure gauge.
 - c Safety valve.
 - d Approved method for filling the system.
 Refer to BS 7074:1 for further guidance.
- 3 The expansion vessel can be fitted in either the return or flow pipework in any of the recommended positions as shown in Fig. 12. To reduce the operating temperature of the expansion vessel diaphragm, position it below the pipe to which it is connected. The expansion vessel may be positioned away from the system, providing the connecting pipe is not less than 13 mm diameter.
- 4 The pressure gauge should have an operating range of 0 to 4 bar.
- 5 The safety valve, set to operate at 2.5 bar, should be fitted in the flow pipework near to the boiler. The pipework between the safety valve and boiler must be unrestricted, i.e. no valves. The safety valve should be connected to a discharge pipe which will allow the discharge to be seen, but cannot cause injury to persons or property.

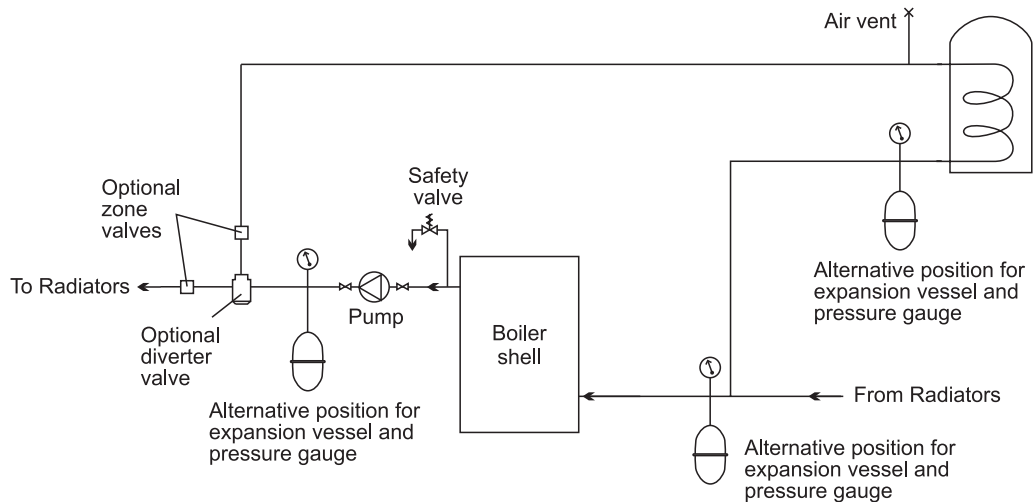

Fig. 12 Sealed system

4 - GENERAL BOILER INFORMATION

- 6 Provision should be made to replace water lost from the system. This can be done manually (where allowed by the local water undertaking) using an approved filling loop arrangement incorporating a double check valve assembly.
- 7 An automatic air vent should be fitted to the highest point of the system as the air vent fitted to the boiler is for venting the boiler only.
- 8 The system design pressure (cold) should be between 0.5 and 1.0 bar. This pressure is equivalent to the maximum static head in bar + 0.3 (1 bar = 10.2 metres of water).
- 9 All fittings used in the system must be able to withstand pressures up to 3 bar.
- 10 Radiator valves must comply with the requirements of BS 2767(10):1972.
- 11 One or more drain taps (to BS 2879) must be used to allow the system to be completely drained.
- 12 For proprietary expansion vessel/valve/gauge packs, refer to the manufacturers instructions for the correct location on the heating system.
13. An automatic filling valve should not be fitted.

4.10 Water connections - Sealed system kit

Also refer to Sections 6.5 and 6.6.

- 1 A 15 mm discharge pipe must be connected to the safety valve outlet connection. The pipework between the safety valve and the boiler must be unrestricted, i.e. no valves. The discharge pipe should terminate so that it cannot cause injury to persons or property.
- 2 A 15 mm double check valve ballofix type valve is provided on the flexible filling loop hose for connection of the cold mains supply to the heating system. The cold mains supply should terminate inside the boiler casing.
- 3 A drain cock is fitted at the bottom on the front of the boiler to allow the heating system to be drained
- 4 The expansion vessel is connected via a flexible hose to allow it to be moved to gain access to the baffle cleaning cover. When replacing the vessel, care should be taken to ensure that the flexible connecting hose is not twisted.

4.11 Underfloor heating systems

On underfloor systems it is essential that the return temperature **must be** maintained above 40° C to prevent internal corrosion of the boiler water jacket.

4.12 Pipework materials

General - Grant boilers are compatible with both copper and plastic pipe. Where plastic pipe is used it **must** be of the oxygen barrier type and be of the correct class (to BS 7291:Part 1:1990) for the application concerned.

IMPORTANT: The first metre of pipework connected to both the heating flow and return connections of the boiler **must** be made in copper on all types of system - sealed or open-vented.

Sealed systems - If plastic pipe is to be used, the installer must check with the plastic pipe manufacturer that the pipe to be used is suitable for the temperature and pressures concerned. Pipe must be Class S to BS 7291: Part 1:1990.

Underfloor systems - Plastic pipe may be used on Underfloor systems where the plastic pipe is fitted **after** the thermostatic mixing valve. Copper tube **must** be used for at least the first metre of flow and return primary pipework between the boiler and the underfloor mixing/blending valves.

5 - CONDENSATE DISPOSAL

5.1 General requirements

When in condensing mode the Grant Vortex boilers produce condensate from the water vapour in the flue gases. This condensate is slightly acidic with a pH value of around 3 (similar to vinegar). Provision must be made for the safe and effective disposal of this condensate.

Condensate can be disposed of using one of the following methods of connection:

Internal connection (preferred option)

- into an internal domestic waste system (from kitchen sink, washing machine, etc.)
- directly into the soil stack

External connection

- into an external soil stack
- into an external drain or gully
- into a rainwater hopper (that is part of a combined system where sewer carries both rainwater and foul water)
- purpose made soakaway

All condensate disposal pipes **MUST** be fitted with a trap - whether they are connected internally or externally to a domestic waste system/soil stack or run externally to a gully, hopper or soakaway.

5.2 Connections

Connections into a rainwater hopper, external drain or gully should be terminated inside the hopper/drain/gully below the grid level but above the water level.

Condensate disposal pipes should not be connected directly into rainwater downpipes or to waste/soil systems connected to septic tanks.

Condensate should not be discharged into 'grey water' systems that re-use water used in the home (not including water from toilets).

It should be noted that connection of a condensate pipe to the drain may be subject to local Building Control requirements.

5.3 Pipework

Condensate disposal pipework must be plastic (plastic waste or overflow pipe is suitable).

IMPORTANT: Copper or steel pipe is **NOT** suitable and **MUST NOT** be used for condensate disposal.

Condensate disposal pipes should have a minimum 'nominal' diameter of 22 mm (¾") - e.g. use 21.5 mm OD polypropylene overflow pipe.

Condensate disposal pipes must be fitted with a fall (away from the boiler) of at least 2.5° (~45 mm fall per metre run).

Note: Where it is not possible for the pipe to fall towards the point of discharge - either internally into a waste system or externally to a gully (e.g. for boilers installed in a basement), it will be necessary to use a condensate pump.

Condensate disposal pipes should be kept as short as possible and the number of bends kept to a minimum.

Pipes should be adequately fixed to prevent sagging, i.e. at no more than 0.5 metre intervals.

External pipework

Ideally, external pipework, or pipework in unheated areas, should be avoided. If unavoidable, external pipework should be kept as short as possible (less than 3 metres) and 32 mm waste pipe used to minimise the risk of ice blocking the pipe in freezing conditions.

The number of bends, fittings and joints on external pipes should be kept to a minimum to reduce the risk of trapping condensate.

Note: For boiler installed in an unheated area such as an outhouse or garage, all condensate pipework should be considered as an 'external'.

5.4 Condensate soakaway

To keep external pipework to a minimum, locate the soakaway as close as possible to the boiler but ensure it is at least 1 metre from building foundations and away from other services, e.g. gas, electricity, etc.

The condensate pipe may be run above or below ground level and can enter either the top or side of the soakaway tube. Refer to Fig.13.

Ensure that the drainage holes in the soakaway tube face away from the building.

Backfill both the soakaway tube, and the hole around it, with 10 mm limestone chippings.

5 - CONDENSATE DISPOSAL

Only use a soakaway where the soil is porous and drains easily. **Do not use in clay soils or where the soil is poorly drained.**

WARNING: Any damage due to condensate backing up into the boiler due to a high water table, in the case of a soakaway, or flooded drains when the condensate disposal is via a gulley or soil stack, is not covered by the Grant product warranty.

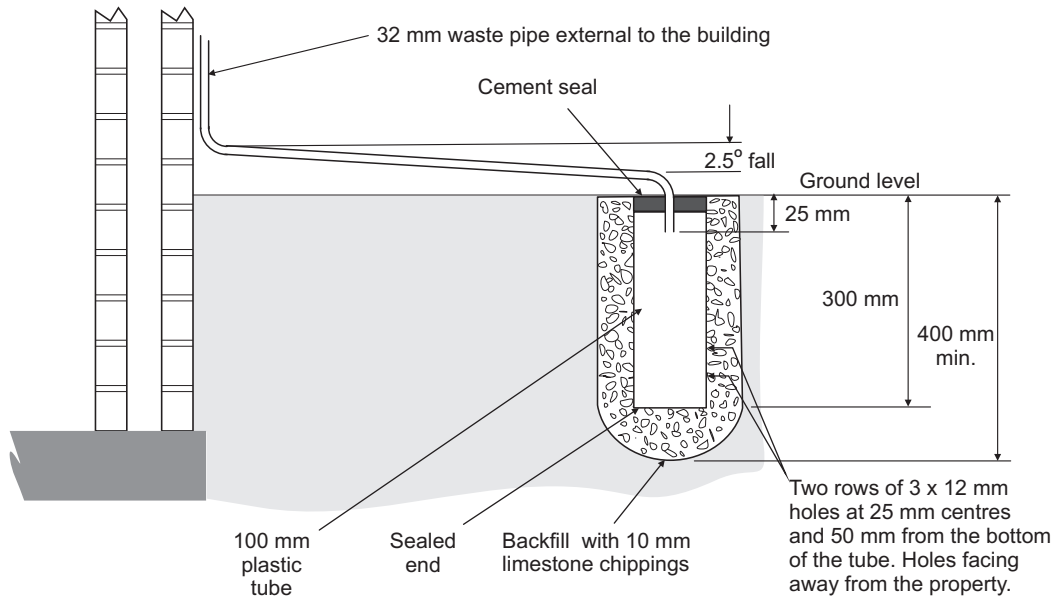

Fig. 13 - Purpose made condensate soakaway

5.5 Condensate trap

Grant Vortex External Modules are supplied with a factory-fitted condensate trap to provide the required 75 mm water seal in the condensate discharge pipe from the boiler.

This trap incorporates a float (which will create a seal when the trap is empty) and an overflow warning outlet (fitted with a plastic sealing cap), See Fig. 14.

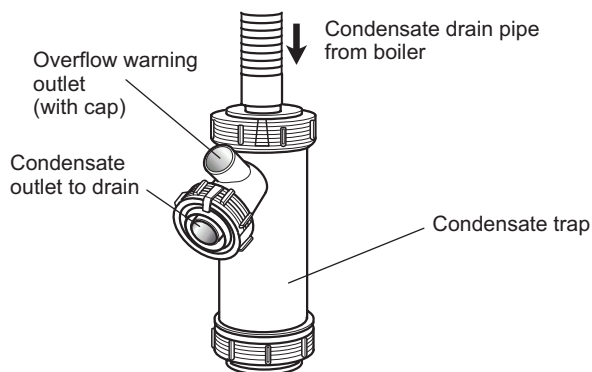

Fig. 14 - Condensate trap

The trap is factory-fitted inside the boiler casing, mounted in the rear of the boiler (opposite end to the burner) on the inside of the right hand side panel - in an accessible position to allow for routine maintenance. See Fig. 11.

A flexible hose connects the outlet of the condensing heat exchanger to the trap inlet. Ensure the straight connector on the hose is fully pushed onto the 'top hat' inlet connector of the trap.

With the trap fitted inside the boiler casing, the sealing cap **MUST** be fitted.

If connecting the condensate discharge (either internally or externally) into a waste system or soil stack - the sealing cap **MUST** be fitted in the trap outlet.

5.6 Condensate disposal pipework

The condensate trap outlet is at an angle of 48° below the horizontal. This is to automatically give a 3° fall on any 'horizontal' runs of condensate disposal pipe. Refer to Fig.13.

The outlet of the trap will accept 21.5 mm to 23 mm OD Polypropylene overflow pipe for the condensate discharge pipe.

Possible routes for disposal pipework

The casing of the Vortex External Module has several 50 mm diameter openings in both the sides and base of the casing. These are designed to allow pipework to pass through the casing, as required, to suit the installation. These openings can be used to allow the condensate disposal pipe to exit the casing in one of the following ways:

Side outlet – The lower opening on either side of the boiler casing can allow the condensate disposal pipe to be installed as follows:

- Connection to an internal stack – passing back through the wall of the house
- Connection to an external soil stack adjacent to the boiler
- Discharge into an adjacent (external) drain or gulley
- Discharge into a soakaway – with pipe either above or below ground level

Bottom outlet – There are three openings in the base of the boiler casing that can allow the condensate disposal pipe to be installed as follows:

- Discharge into a drain or gulley beneath the boiler (e.g. drain built in to the concrete base for the boiler)
- Discharge into a soakaway – with pipe below ground level

5.7 Inspection and cleaning of trap

The trap **MUST** be checked at regular intervals (e.g. on every annual service) and cleaned as necessary to ensure that it is clear and able to operate.

Note: The bottom bowl is sealed to the trap body and cannot be removed.

To inspect and clean the trap:

- 1 Disconnect flexible condensate hose from inlet connector.
- 2 Unscrew the outlet connection nut.
- 3 Remove the outlet connector and nut from trap.
- 4 Remove trap from bracket.
- 5 Remove float from trap – clean if necessary.
- 6 Inspect inside of trap and clean as necessary.
- 7 Re-assemble trap, re-fit to boiler and re-connect flexible hose. Ensure that hose is fully pushed onto the trap inlet connector.

IMPORTANT: Failure to regularly check and clean the condensate trap may result in damage to the boiler and will not be covered by the Product Warranty.

6 - BOILER INSTALLATION

6.1 Unpack the boiler

- 1 Carefully remove the packaging from the boiler and lift it off the pallet.
- 2 The flue terminal guard is supplied loose inside the boiler.
- 3 Remove the case top panel (four screws).
- 4 The flue may exit the casing from the left, right or rear of the casing. The casing has two removable blanking panels and a flue exit panel. Fit the panel with the flue exit hole and seal in the required position.
- 5 Slacken the wing nuts holding the flue elbow and rotate the elbow to the required direction for the flue to exit the casing.
- 6 Push the end of the flue terminal section with the red seal through the seal in the casing. The terminal has been factory lubricated. Take care not to dislodge or damage the red seals.
- 7 Carefully insert the terminal into the flue elbow until the bend of the terminal contacts the outer casing, then, pull the terminal forward approximately 25 mm and rotate the bend so that the outlet is **horizontal**.
- 8 Tighten the wing nuts holding the flue elbow and fit the stainless steel flue guard using the two screws provided.
- 9 The top panel of the casing has been designed so that it may be fitted to create a slight slope away from the side positioned against the wall. To tilt the top panel, loosen the four top panel casing screws, one at each corner and push down on the side furthest from the wall. Tighten the screws. See Fig. 15.

6.2 Preparations for installation

- 1 If the boiler is to be fitted against the wall, prepare the wall to accept the heating system pipework. To mark the wall for drilling, refer to Fig. 1 for the positions of the pipework openings in the enclosure sides.

Note: Pipework should be insulated where it passes through the wall into the boiler enclosure.

If the boiler is to be installed 'free standing' (i.e. away from a wall) and the pipework run underground, slide away the covers to open the two pipe openings in the base of the boiler enclosure. Using a sharp knife, cut through the polystyrene in the base, around the edge of the holes, to allow the flow and return pipes to enter the enclosure.

- 2 The electrical supply to the boiler should be routed through the wall in a suitable conduit, such that it enters the boiler enclosure via one of the unused pipework openings. The cable can be routed to the front of the boiler, for connection to the boiler control panel, either over the top or beneath the boiler heat exchanger. Heat resistant PVC cable, of at least 1.0 mm² cross section should be used within the boiler enclosure.

Rear Exit - The flue must discharge away from the building.

Side Exit - The flue should discharge towards the rear of the casing to prevent flue gases re-entering the boiler casing through the air inlet vents on the casing front door.

The flue terminal must be fitted horizontally to prevent dripping from the end of the terminal.

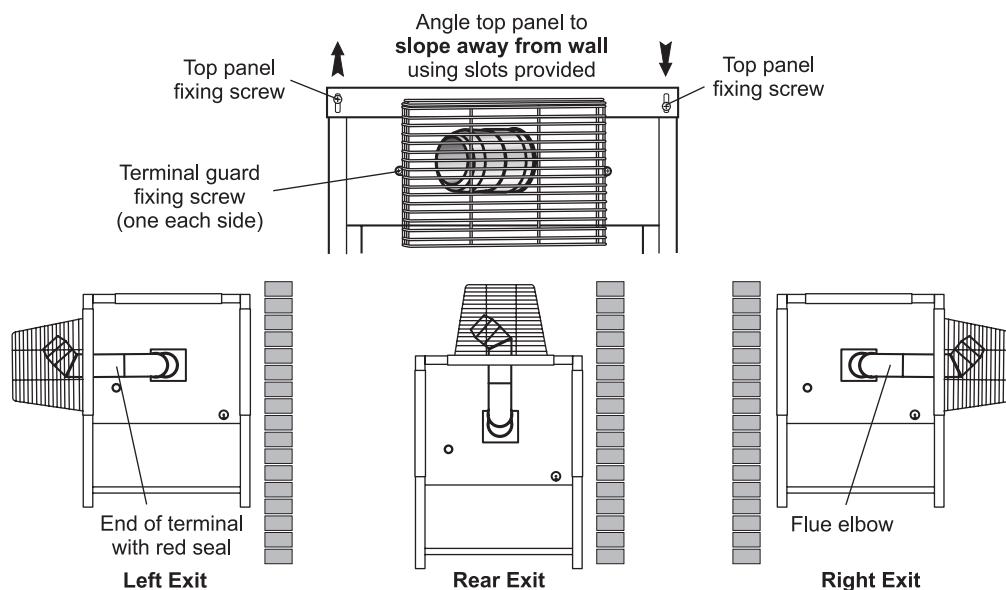

Fig. 15

- The oil supply line should be installed up to the position of the boiler. Refer to Section 4.4.2 for details. The final connection into the boiler enclosure can be made with 10 mm soft copper, routed along the base of the enclosure (either between the enclosure and wall or in front of the enclosure) to enter through one of the holes located in the bottom edge side panel, at the front (burner) end.

6.3 Make the water connections

Refer to Section 4.8 and 4.19 and Figs. 8, 9, 10 or 11. for the size, type and position of the connections.

The Flow and Return pipework can be routed to either side of the boiler as required.

For condensate disposal pipework refer to Section 5.

- To gain access to the water connections, remove the two screws securing the bottom of the back panel and remove it by withdrawing it forwards at the bottom. Remove the top casing panel.
- To gain access to the burner, remove the front panel by turning the handle and withdrawing it forwards at the bottom..
- If required, fit the Grant sealed system kit, see Section 6.5.
- Carefully manoeuvre the boiler in position to line up with pipework through the wall. Complete the water connections.

Note: Check that the baffles are in position and that the cleaning cover is correctly fitted and a good seal made.

- If the boiler is installed against a wall, fit the wall flashing strip. Position the strip with the bottom edge of the wider flange 20 mm above the enclosure top panel, with the narrow flange (with the three fixing holes) flat against the wall. The strip should overhang the top panel by an equal amount at each end.
Mark the position of the three fixing holes onto the wall, drill and plug the wall and secure the strip with suitable screws (not supplied).
- Fill and vent the water system and check for leaks, rectifying where necessary.

If the Grant sealed system kit is fitted, refer to Section 6.6 for details on filling and venting the sealed heating system.

6.4 Flue systems

See Figs. 16 and 17

Where it is not possible to terminate the factory supplied low level flue, there are two alternative options;

Plume diverter kit - This single wall stainless steel flue accessory is designed to divert the flue gases up and terminate at a higher level than the factory supplied terminal. When fitting the plume diverter kit, follow the instructions supplied with the kit. See Fig. 16.

Horizontal system - This option uses a straight boiler connector, elbows and extensions as shown in Fig. 17.

A complete list of flue components are given on page 25.

All flue components are stainless steel and fully insulated with 'O' ring seals and locking bands.

- The flue must terminate in a down draught free area, i.e. at least 600 mm above the point of exit through the roof or preferably above the ridge level.
- The condensate may be allowed to run back into the boiler. A condensate drain at the base of the flue system is not required.
- The flue terminal must be at least 600 mm from any opening into the building, and 600 mm above any vertical structure or wall less than a horizontal distance of 750 mm from the terminal.

It is important to ensure that the flue system is sealed and that condensate cannot escape. Up to 1.5 l/h of condensate can be produced in a conventional flue system.

6 - BOILER INSTALLATION

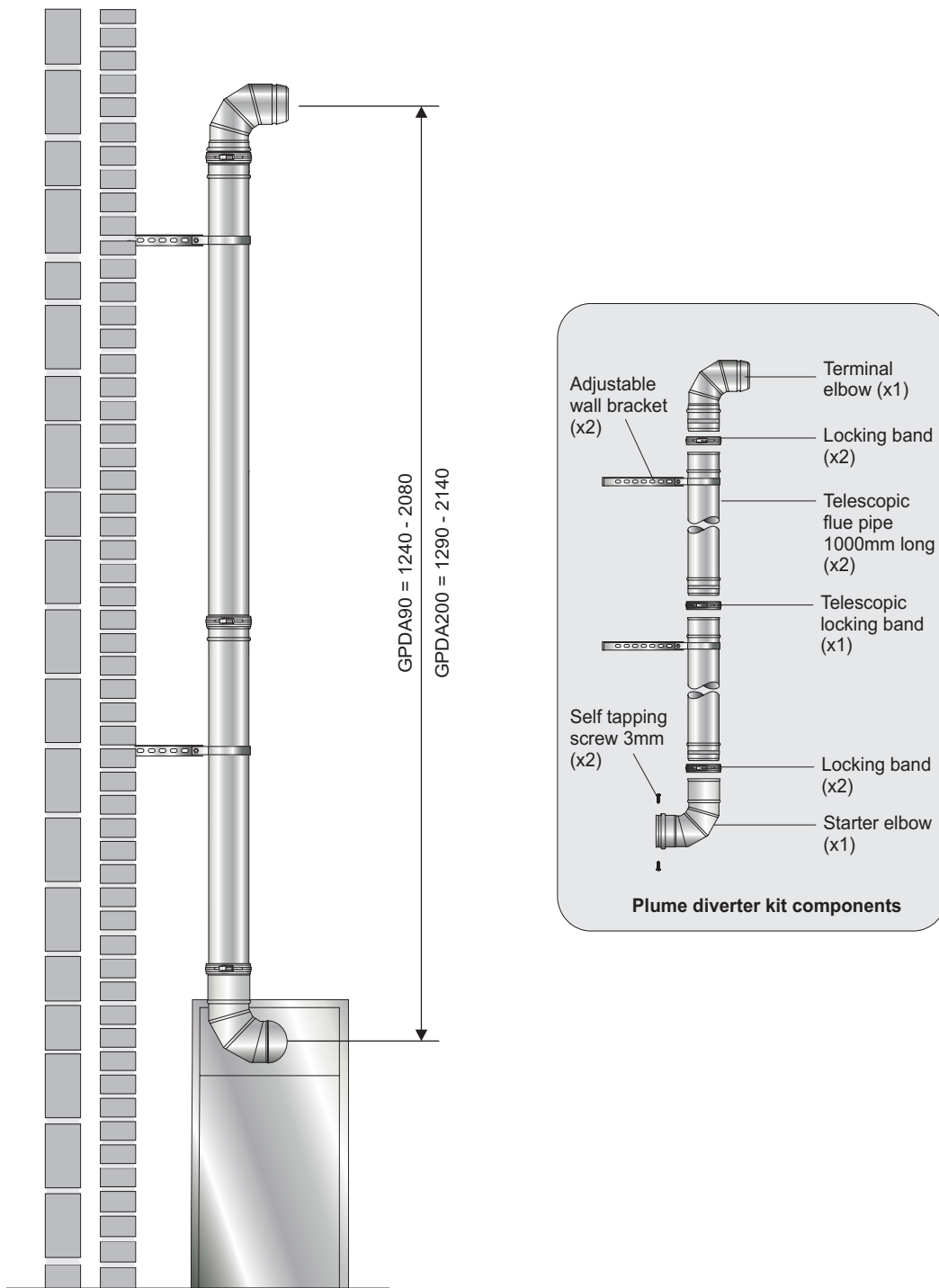

Fig. 16 - Plume diverter kit (Outdoor boiler)

6 - BOILER INSTALLATION

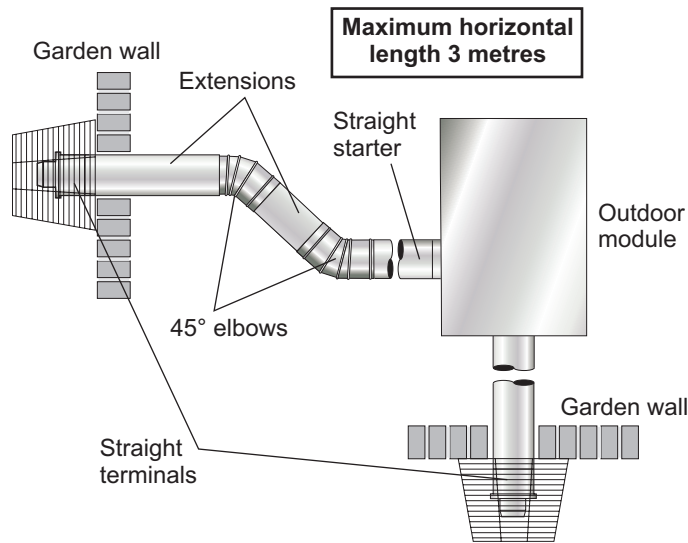

Fig. 17 - Horizontal external flue

The following flue components are available from your local stockist

50/70 and 50/90 models	
Item	Part No.
External starter elbow	GKM90
External starter - straight	GKM90C
150 mm extension	GX150/90
250 mm extension	GX250/90
450 mm extension	GX450/90
950 mm extension	GX950/90
195-270 mm adjustable extension	GXA250/90
45° elbow	GE45/90
High level terminal	GTH90
Vertical terminal	GTV90
Wall bracket - standard	GWB90
Wall bracket - extended	GEB90
Straight terminal - Horizontal flue	GTL90

90/120, 120/155, 155/200 and 200/240 models	
Item	Part No.
External starter elbow	GKM200
External starter - straight	GKM200C
150 mm extension	GX150/200
250 mm extension	GX250/200
450 mm extension	GX450/200
950 mm extension	GX950/200
195-270 mm adjustable extension	GXA250/200
45° elbow	GE45/200
High level terminal	GTH200
Vertical terminal	GTV200
Wall bracket - standard	GWB200
Wall bracket - extended	GEB200
Straight terminal - Horizontal flue	GTL200

6 - BOILER INSTALLATION

6.5a Sealed system kit - 50/70

See Figs. 18 and 19

- 1 The kit includes the following items:
 - Pressure relief valve and automatic air vent
 - Manifold pipe
 - 10 litre expansion vessel with flexible hose and sealing washer
 - Expansion vessel mounting bracket
 - Filling loop kit
 - Pressure gauge (mounted on compression tee)
 - 6 m head circulating pump with 22 mm gate type valves
 - 15 mm copper pressure relief valve discharge pipe (in two pieces with push-fit connector)
 - Pump support bracket (with fixing screws)
- 2 Unscrew and remove the two nuts and washers from the two cleaning door studs. Remove cleaning door from boiler.
- 3 Remove the ½" BSP black iron plug from the front of the boiler waterway, using a ¾" drive socket wrench.
- 4 Fit the ½" BSP straight connector end of the flexible expansion vessel hose into the tapping on the front of the waterway using a suitable thread sealant.
- 5 Fit the ¾" BSP connection on the flexible expansion vessel hose to the vessel using the black rubber sealing washer supplied and tighten the union nut.
- 6 Replace the cleaning door on the two door studs. Fit the expansion vessel mounting bracket onto the studs. Replace the nuts and washers and re-tighten to secure door and bracket.

- 7 Fit the pressure relief valve and automatic air vent onto the manifold pipe. Then fit the manifold pipe end into the 22mm compression connector on the boiler flow pipe. Refer to Fig. 18.

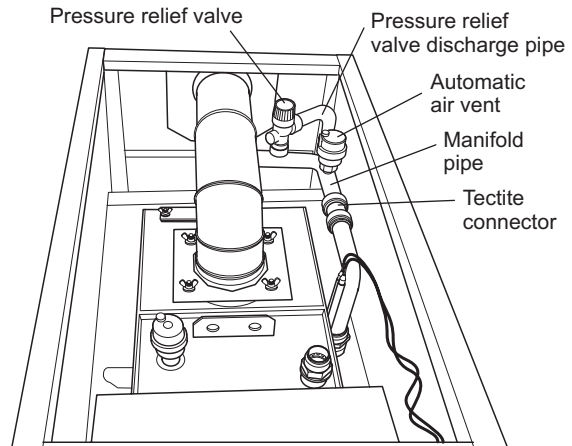

Fig. 18 - 50/70 top view (showing automatic air vent, pressure relief valve and manifold)

- 8 Fit both 22 mm pump valves to the circulating pump using the sealing washers provided.
- 9 Fit the pump support bracket, with the screws provided, using the two holes in the left hand side panel flange (viewed from rear of boiler as shown in Fig. 19).

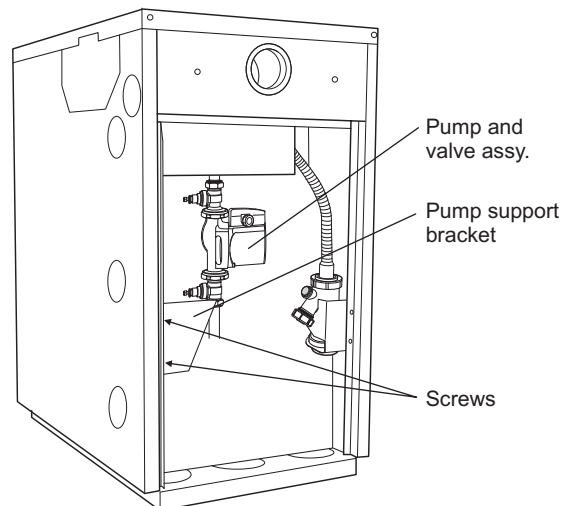

Fig. 19 - 50/70 rear view (showing pump assembly)

- 10 Fit the pump/pump valve assembly to the end of the pressure relief valve/auto air vent manifold pipe. Ensure that the pump shaft is horizontal and the pump motor is facing towards the right side of the boiler (viewed from the rear as shown in Fig. 19). The flow arrow on the body of the pump must face in the required direction of flow – away from the boiler flow connection – downwards in this case.
- 11 Ensure that the pump/valve assembly is supported by the bracket. The upper part of the lower valve should rest on the support bracket, with the body of the valve passing through the cut-out. Connect the flow pipework to the lower pump valve.
- 12 Assemble the two sections of the pressure relief valve discharge pipe using the 15 mm straight push-fit connector provided. Adjust the pressure relief valve so that the outlet points to the rear left corner of the boiler (viewed from the rear of the boiler).
- 13 Fit the pressure relief valve discharge pipe to the pressure relief valve outlet using the nut and olive provided. Route the pipe down the left hand rear side of the boiler and locate the lower end through the slot in the bottom flange of the left hand side panel.
- 14 The circulating pump may be wired into the boiler control panel if required. Refer to Section 10.
- 15 The pressure gauge and filling loop should be installed in a convenient position inside the building.

6.5b Sealed system kit - 50/90

See Fig. 20

- 1 The kit includes the following items:
 - Pressure relief valve and automatic air vent
 - Manifold pipe
 - 12 litre expansion vessel with flexible hose and sealing washer
 - Filling loop kit
 - Pressure gauge (mounted on compression Tee)
 - 6 m head circulating pump with 22 mm gate type valves
 - 15 mm copper pressure relief valve discharge pipe
- 2 Remove the ½” BSP black iron plug from the front of the boiler waterway, using a ¾” drive socket wrench.
- 3 Fit the ½” BSP straight end of the flexible expansion vessel hose to the tapping on the front of the waterway using a suitable thread sealant.
- 4 Position the 12 litre expansion vessel on the front of the boiler combustion door locating the bracket into the slot of the combustion door.
- 5 Fit the ¾” BSP connection of the flexible expansion vessel hose to the vessel using the black rubber washer supplied and tighten the nut.
- 6 Fit the 22 mm compression elbow onto the boiler flow connection.
- 7 Fit the pressure relief valve and automatic air vent onto the manifold pipe. Then fit the manifold pipe end into the 22mm compression connector on the boiler flow pipe.
- 8 Fit both 22 mm pump valves to the circulating pump using the sealing washers supplied.
- 9 Fit the pump assembly to the automatic air vent/pressure relief valve assembly ensuring that the pump shaft is horizontal and the pump motor is facing towards the front of the boiler. The flow arrow on the body of the pump must face in the direction of flow away from the boiler connection.
- 10 Fit the pressure relief valve discharge pipe to the pressure relief valve using the nut and olive supplied. Route the discharge pipe through the slot in the base of the right hand side panel. Push the panel insulation back to expose the slot.
- 11 The circulating pump may be wired into the boiler control panel if required. Refer to Section 10.
- 12 The pressure gauge and filling loop should be installed in a convenient position inside the building.

6.5c Sealed system kit - 90/120 and 120/155

See Fig. 20

- The kit includes the following items:

Pressure relief valve and automatic air vent assembly
 Manifold pipe
 16 litre expansion vessel with flexible hose and sealing washer
 Filling loop kit
 Pressure gauge(mounted on compression Tee)
 7 m head circulating pump with 28 mm gate type valves
 15 mm copper pressure relief valve discharge pipe

- Remove the ½" BSP black iron plug from the front of the boiler waterway, using a ¾" drive socket wrench.
- Fit the ½" BSP straight end of the flexible expansion vessel hose to the tapping on the front of the waterway using a suitable thread sealant.
- Remove the nuts and washers from the boiler combustion door.

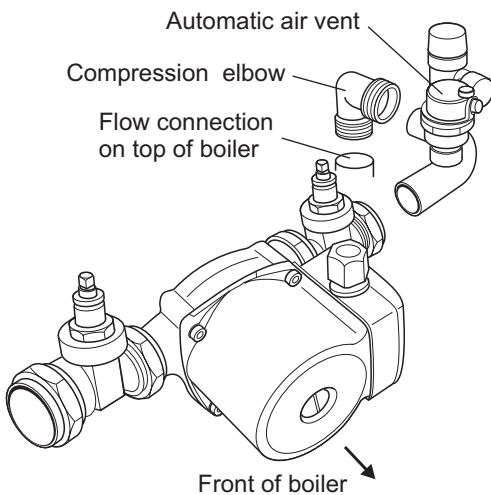

Fig. 20 - Sealed system pump assembly

- Fit the vessel support bracket to the bottom two studs of the combustion door and refit the nuts and washers. Tighten to ensure an adequate seal is made.
- Position the 16 litre expansion vessel onto the support bracket in front of the boiler combustion door locating the top of the vessel behind the control panel first.
- Screw in the locking screw on the base of the bracket to secure the vessel in place.
- Fit the ¾" BSP connection of the flexible expansion vessel hose to the vessel using the black rubber washer supplied and tighten the nut.

- Fit the 28 mm compression elbow onto the boiler flow connection.
- Fit the pressure relief valve and automatic air vent onto the manifold pipe. Then fit the manifold pipe end into the 28mm compression connector on the boiler flow pipe.
- Fit both 28 mm pump valves to the circulating pump using the sealing washers supplied.
- Fit the pump assembly to the automatic air vent/ pressure relief valve assembly ensuring that the pump shaft is horizontal and the pump motor is facing towards the front of the boiler. The flow arrow on the body of the pump must face in the direction of flow away from the boiler connection.
- Fit the pressure relief valve discharge pipe to the pressure relief valve using the nut and olive supplied. Route the discharge pipe through the slot in the base of the right hand side panel. Push the panel insulation back to expose the slot.
- The circulating pump may be wired into the boiler control panel if required. Refer to Section 10.

6.6 Sealed system expansion vessel pressure

The expansion vessel fitted is supplied with a charge pressure of 1.0 bar (equivalent to a max. static head of 10.2 metres). The charge pressure must not be less than the actual static head at the point of connection. Do not pressurise the vessel above 1.5 bar.

The air pressure in the vessel must be checked annually.

The central heating system volume, using the expansion vessel as supplied, must not exceed the recommended volumes. If the system volume is greater, an extra expansion vessel (complying with BS 4841) must be fitted as close as possible to the central heating return connection on the boiler. The charge pressure of the extra vessel must be the same as the vessel fitted in the boiler. Refer to BS 7074:1 for further guidance.

The air charge pressure may be checked using a tyre pressure gauge on the expansion vessel Schraeder valve. The vessel may be re-pressurised using a suitable pump. When checking the air pressure the water in the heating system must be cold and the system pressure reduced to zero.

6.7 Connect the power supply

See wiring diagrams in Section 10

Note: A test switch is fitted to the control panel to allow the boiler to be test-fired. When On, the switch by-passes the external control system.

- 1 Undo the three screws and remove the lefthand cover from the control panel to gain access to the boiler terminal block.
- 2 Pass the mains power supply cable through the cable grommet in the control panel, through the cable clamp and connect to the terminal block as follows:-
 - Live (brown) to terminal 2 - marked permanent live
 - Neutral (blue) to terminal 3 - marked mains neutral
 - Earth (green/yellow) to terminal 4 - marked mains earth
- 3 If the circulating pump is to be fitted within the boiler enclosure, the pump live must be connected to terminal 7 of the boiler terminal block.

Pass the pump power supply cable through the cable grommet in the control panel, through the cable clamp and connect to the terminal block as follows:-

 - Earth (green/yellow) to terminal 10 - marked E
 - Neutral (blue) to terminal 9 - marked N
 - Live (brown) to terminal 7

Connecting the pump in this way allows it to be isolated using the isolating switch fitted in the boiler control panel, for servicing or maintenance work.
- 4 Ensure that the cable clamp is tightened and that all cables are secure.
- 5 Replace the cover on the control panel, with the yellow warning label facing outwards and secure with the three screws.

Do not switch on the electrical power to the External Module at this stage.

6.8 Connect the fuel supply

See Fig. 6

If a two pipe system is to be used refer to Section 4.4.6.

- 1 Remove the oil inlet plug from the fuel pump and connect the elbow of the flexible fuel hose supplied with the boiler.
- 2 Connect the flexible fuel hose to the rigid supply using the adaptor supplied. The supply enters the enclosure through one of the holes in the bottom of the side panels.

6.9 Fill the sealed system

- 1 Automatic air vent(s) are fitted to the top of the boiler. Check that the small cap on the top of each air vent is screwed on fully, then unscrew it one complete turn - the cap remains in this position from now on.
- 2 If the flexible filling loop is used to fill the system, ensure it is connected and that the valve connecting it to the system is open and the valve at the front is closed. A valve is open when the operating lever is in line with the valve, and closed when it is at right angles to it.
- 3 Ensure that the mains cold water supply valve is open (operating lever in line with the valve), then turn on the mains cold water supply and gradually open the front valve on the filling loop until water is heard to flow.
- 4 Vent each radiator in turn, starting with the lowest one in the system, to remove air.
- 5 It is important that the pump is properly vented to avoid it running dry and damaging its bearings. To gain access to the pump for venting it is necessary to remove the top panel, or rear panel (50/70 model only).

Remove the cap, then unscrew and remove the plug from the centre of the pump. Using a suitable screwdriver rotate the exposed spindle about one turn. Replace the plug and cap.
- 6 Check the operation of the safety valve by turning the head anticlockwise until it clicks. The click is the safety valve head lifting off its seat allowing water to escape from the system.

Check that this is actually happening.
- 7 Continue to fill the system until the pressure gauge indicates between 0.5 and 1.0 bar. Close the fill point valve and check the system for water soundness, rectifying where necessary. Water may be released from the system by manually operating the safety valve until the system design pressure is obtained.

6 - BOILER INSTALLATION

- 8 The system design pressure (cold) should be between 0.5 bar and 1.0 bar. The pressure is equivalent to the maximum static head in bar + 0.3 (1 bar = 10.2 metres of water), where the static head is the vertical height from the centre of the expansion vessel to the highest point of the system.
- 9 Close the valves either side of the filling loop and disconnect the loop.

6.10 Burner components

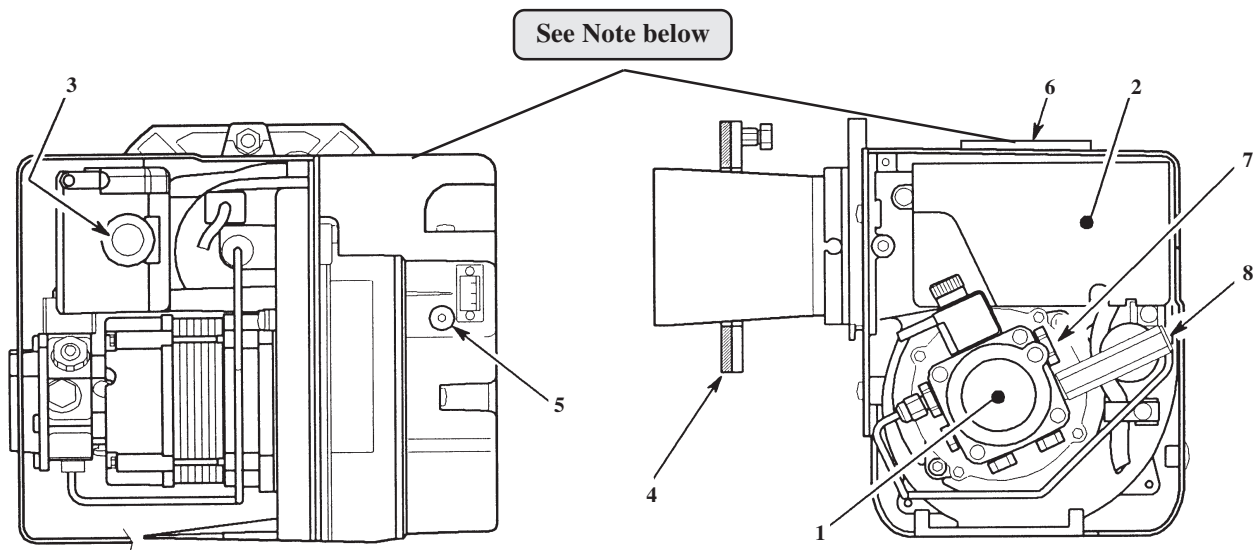

Fig. 21 - RDB burner components

- | | |
|--|--|
| 1 Pump | 5 Air damper adjustment screw |
| 2 Control box | 6 Air supply tube connection (balanced flue) |
| 3 Reset button with lock-out lamp | 7 Pump pressure adjustment screw |
| 4 Flange with gasket (do not remove from boiler) | 8 Pressure gauge connection |

Note:

Remove the factory fitted air inlet spigot adaptor (item 6, above) from the air intake on the top right hand side of the burner and fit the grey plastic air inlet grille in its place.

Boiler Passport - The Installer is responsible for completing the boiler passport supplied with this boiler and returning the paperwork to Grant Engineering (IRL) Ltd.. This appliance must be correctly commissioned in accordance with the appliance instructions and the details returned to Grant Engineering (IRL) Ltd. using the address shown on the back of this manual.

Refer to Fig. 22 for boiler controls

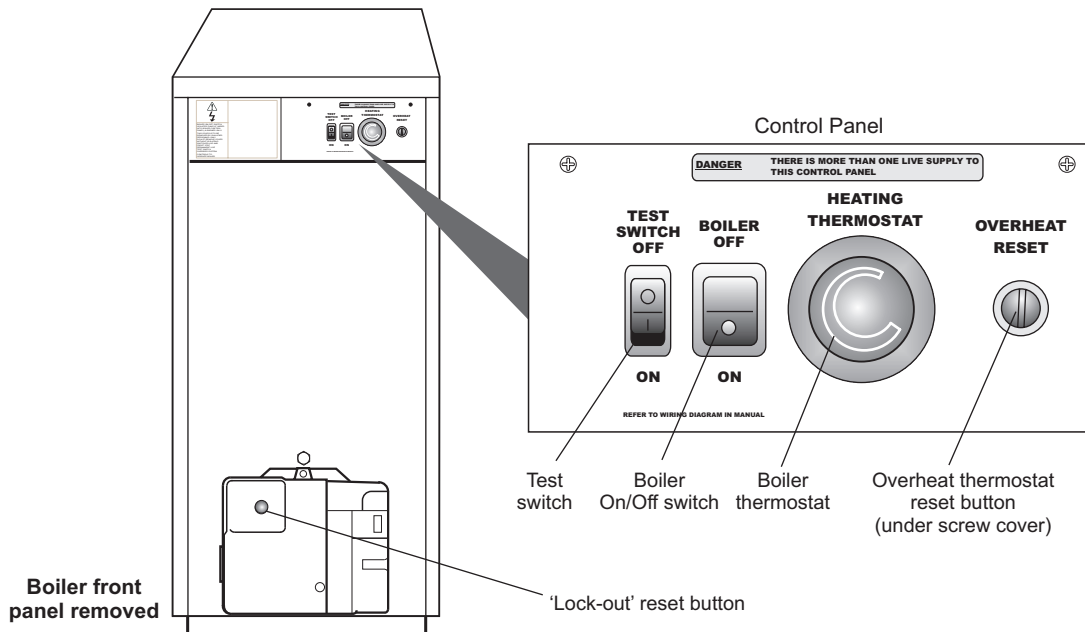

Fig. 22

Note: Check that the baffles are in position and that the cleaning cover is correctly fitted and a good seal made.

IMPORTANT:

Check that the turbulators are in position and that the ends are vertical (see Fig. 28).

Note: If the 50/90 model is down-rated to 68,240 or 51,200 Btu/h, or the 120/155 to 123,000 Btu/h the burner head must be changed. See Section 3.3 and Sections 9.2 and 9.4.

The Riello RDB 2.2 burner fitted to 50/70 boiler incorporates a secondary air adjustment shutter located within the air inlet housing. If the burner is to be down-rated to the minimum output of 51,200 Btu/h, it is essential that this internal shutter be correctly adjusted. To do this proceed as follows:

1. Switch off the boiler and isolate from the electrical supply.
2. Remove the burner from the boiler.
3. Undo the two screws and remove the air inlet cover from the side of the burner.

4. The secondary air shutter disc is factory set in position 'C' – i.e. with the cut-out marked C located against the die-cast boss on the fan housing. See Fig 23.
5. Remove the screw from the centre of the air shutter disc, and re-position the disc such that the cut-out 'B' (see Section 3.3) is located against the cast boss on the fan housing. Replace the screw in the centre of the air shutter disc and tighten.
6. Re-fit the air inlet cover to the side of the burner.
7. Change nozzle - Refer to Section 3.3 for correct nozzle for new output setting.
8. Re-fit the burner to the boiler.

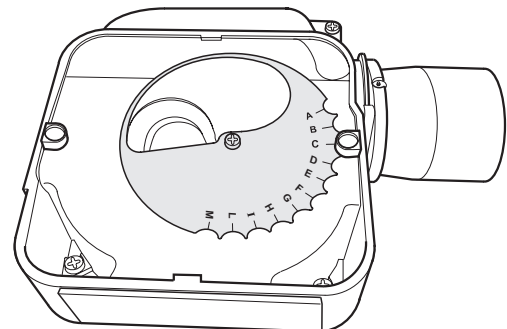

Fig. 23 - 50/70 burner air adjuster disc (shown set to position 'C')

7 - COMMISSIONING

It is important that the following commissioning procedure is carried out to ensure safe and efficient operation of the boiler.

- 1 Check that the water system has been vented (and pressurised if sealed system) and there are no leaks.

Ensure the flow pipe has been vented.

- 2 Check that all fuel line valves are open.
- 3 Remove the plastic burner cover (two screws) if it was not previously removed.
- 4 Connect a combined vent manifold and pressure gauge to the pressure gauge connection port on the oil pump. See Fig. 21. Open the vent screw on your vent manifold to vent the supply while the pump is running.
- 5 Check that all system controls are calling for heat and turn the boiler thermostat to maximum. Switch on the electricity supply.

Note: The boiler will start as soon as the electricity supply to it is switched on.

- 6 The burner fan should start and the burner should light within about 12 seconds. If the burner does not light and the 'Lock-out' reset button lights, wait for about 45 seconds then press the reset button to restart the ignition process. This procedure may have to be repeated several times during first lighting.
- 7 With the burner alight, check the fuel pressure. Refer to the Technical Information, Section 3.3. Adjust the pressure if necessary - see Fig. 21.
- 8 Operate the boiler until it reaches normal operating temperature. Check oil supply/return pipe for leaks, rectifying where necessary.
- 9 Check the operation of the boiler thermostat. Ensure that by turning it anticlockwise it switches the burner off.
- 10 With the burner alight, re-check the fuel pressure and re-adjust if necessary. Turn the boiler off, remove the pressure gauge and replace the plug in the pump.
- 11 Having ensured that there are no oil leaks, replace the burner cover.
- 12 Relight the boiler and allow it to run for 20 minutes.

Insert combustion probe into the end of the flue terminal to measure the CO₂ level.
Do not use the boiler test point.

- 13 Check the smoke number, if satisfactory check the CO₂. Set the CO₂ to the value given in Section 3.3 for the boiler concerned.

Use the hexagonal key supplied to adjust the burner air damper (see Fig. 21) as required. Turning the screw anti-clockwise closes the damper and increases CO₂ level, turning the screw clockwise opens the damper and reduces CO₂ level. Re-check the smoke number if the damper has been moved. Under no circumstances must the smoke number be above 1.

Note: It is important that the air damper is correctly set.

Note: To obtain the correct CO₂ level, the final flue gas reading must be taken with all casing panels fitted.

- 14 Check the flue gas temperature.
- 15 When the boiler has been adjusted and is running satisfactorily, balance the central heating system by adjusting the radiator lock shield valves. Start with the radiator nearest the boiler and adjust the valves to achieve the required temperature drop across each radiator. If thermostatic radiator valves have been installed, check the system by-pass.
- 16 Switch off the boiler.
- 17 With the system hot, check again for leaks, rectifying where necessary. Drain the system while it is hot to complete the flushing process. Refill and vent (and pressurise if a sealed system) the system.

18 A suitable central heating system inhibitor must be added to protect the system against the effect of corrosion.

- 19 Replace the top, front and rear panels.

Note: After commissioning the boiler complete the boiler passport that comes supplied with the boiler and return the commissioning details to Grant Engineering (IRL) Ltd..

If the boiler is to be left in service with the User, set the controls and room thermostat (if fitted) to the User's requirements.

If the boiler is not to be handed over immediately, close the boiler fuel supply valve and switch off the electricity supply.

If there is any possibility of the boiler being left during frost conditions, then the boiler and system should be drained.

7 - COMMISSIONING

IMPORTANT NOTE:

A combustion test point is provided on the front cleaning door.

This test point is not suitable for measuring the final CO₂ level, smoke number, boiler efficiency or conventional flue draught.

At this test point on the cleaning cover the flue gas temperature reading will be higher than that measured in the flue thus resulting in an inaccurate efficiency reading. To obtain an accurate flue gas CO₂ level, smoke number, temperature and efficiency, the reading can only be measured at the low level flue terminal or the test point on the conventional flue starter elbow where fitted with all the casing panels fitted.

8 - INFORMATION FOR THE USER

The User must be advised (and demonstrated if necessary) of the following important points:-

- 1 How to light and turn off the boiler and how to operate the system controls.
- 2 The precautions necessary to prevent damage to the central heating system and to the building, in the event of the boiler not being in operation during frost conditions.
- 3 The importance of servicing the boiler to ensure safe and efficient operation. This should normally only be required once a year.
- 4 The type of fuel used.
- 5 That any servicing or replacement of parts must only be carried out by a suitably qualified engineer.
- 6 Ensure that the boiler controls and room thermostat (if fitted) are set to the User's requirements.

- 7 If the boiler is used on a sealed heating system, tell the user the system pressure and show them the position of the safety valve discharge pipe.
- 8 Show the User how to reset the overheat thermostat and how to restart the boiler if it goes to 'Lock-out'.

Leave this Instruction manual with the User.

To ensure your continued Boiler Warranty, the annual service must be carried out by an OFTEC Registered Technician or an otherwise competent person.

Use of non-competent persons may invalidate this warranty. A list of OFTEC Registered Technicians is available at www.oftec.org or alternatively telephone OFTEC on 0845 658 5080 (UK) or 01 864 5771 (ROI).

9 - BOILER SERVICING

To ensure efficient operation of the boiler it is recommended that it is checked and serviced as necessary at regular intervals. The frequency of servicing will depend upon the particular installation conditions and usage, but in general once per year should be adequate.

Servicing and replacement of parts must only be carried out by a suitably qualified engineer.

Important: Details of every service should be entered in the boiler passport. This information may be required to validate the Grant extended warranty.

IMPORTANT

Before starting any work on the boiler, or fuel supply please read the health and safety information given in Section 14 on page 43.

Note: A test switch is fitted to the control panel to allow the boiler to be test-fired. When On, the switch by-passes the external control system.

9.1 Important notes prior to servicing

- 1 Check the flue terminal and ensure it is not blocked or damaged.
- 2 Run the boiler and check the operation of its controls.
- 3 Ensure that all water/fuel system connections and fittings are sound. Remake any joints and check the tightness of any fittings that may be leaking.
If the boiler is used on a sealed central heating system, check the system pressure, check the operation of the pressure relief valve and check the expansion vessel air charge. See Section 6.6.
Refill, vent and re-pressurise the system as necessary. See Section 6.9.
- 4 Check that the louvres in the front panel are clear.
- 5 Remove any sludge/water from the fuel tank by opening the sludge valve at the lower end of the tank.
- 6 With the fuel supply valve closed, clean/replace the filter element and clean the filter bowl.
- 7 Flexible fuel supply hoses should be inspected annually when the boiler is serviced and braided hoses replaced every year. If in doubt replace the hoses.

Warning: Before servicing, set the boiler On/Off switch to Off, isolate the electricity supply and close the fuel supply valve. Allow the boiler to cool. The data label on the inside of the case side panel will indicate the nozzle fitted.

9.2 Dismantling prior to servicing

- 1 Remove the front panel by turning the handle and withdrawing it forwards at the bottom.
- 2 Remove the four screws securing the top panel and carefully lift it off, taking care not to damage the insulation.

Note: The top panel has been designed to provide a slight fall away from the side positioned against a wall, the side of the top panel with the fixing screws closer to the bottom edge is the highest side and goes against the wall.

- 3 Remove the burner fixing nut (top of mounting flange) and withdraw the burner.
If required, disconnect the flexible oil hose(s), use a suitable container to prevent any oil spillage.

Note: If two flexible hoses are connected to the burner, identify (mark if necessary) which is the inlet and return if they are to be disconnected.

9.3 Cleaning the boiler

- 1 Remove the nuts and washers securing the front cleaning door and withdraw the door. Take care - it is heavy.
- 2 Remove the baffles as shown in Fig. 24, 25, 26 or 27.
- 3 Remove all deposits from the baffle plates and all the boiler internal surfaces using a stiff brush and scraper if necessary.
- 4 Check the condition of the flue, clean as necessary.
- 5 Check the condition of the front cleaning door seal, replace if necessary.
- 6 Replace the baffles, ensuring they are correctly fitted. See Fig. 24, 25, 26 or 27.
- 7 Pull out the spiral turbulators from the heat exchanger tubes. See Fig. 28.

Note: 50/70 - Ensure that the front handle on the top baffle (No. 4) is correctly located over the front section of baffle No. 3.

Clean the turbulators using a stiff brush
Test the heat exchanger condensate drain by pouring water into one of the lower tubes and observe whether the water discharges from the 22mm condensate outlet. Replace the turbulators.

IMPORTANT: When replacing the turbulators ensure that the flat end sections are all positioned vertically.

9 - BOILER SERVICING

- 8 Replace the front cleaning door, ensuring the seal is in good condition and secure it in position with the nuts and washers previously removed. Tighten to form a seal.
- 9 Remove the condensate trap and check that it is not blocked and is operating correctly, i.e. the float is free to move. Clean the trap and float as required. Refer to Section 5.7.
- 10 Check that the boiler condensate outlet is unobstructed. Clean if necessary.

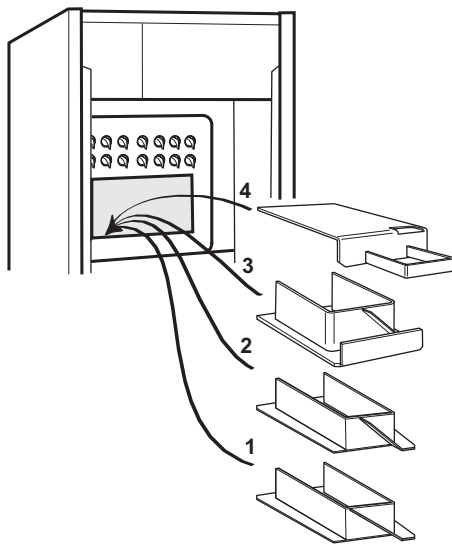

Fig. 24 - 50/70 baffles

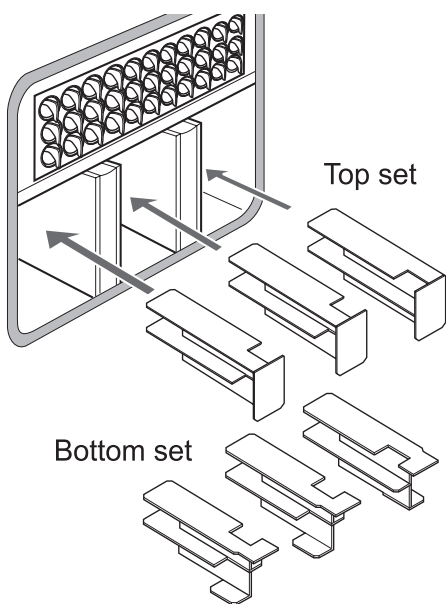

Fig. 26 - 90/120 and 120/155 baffles

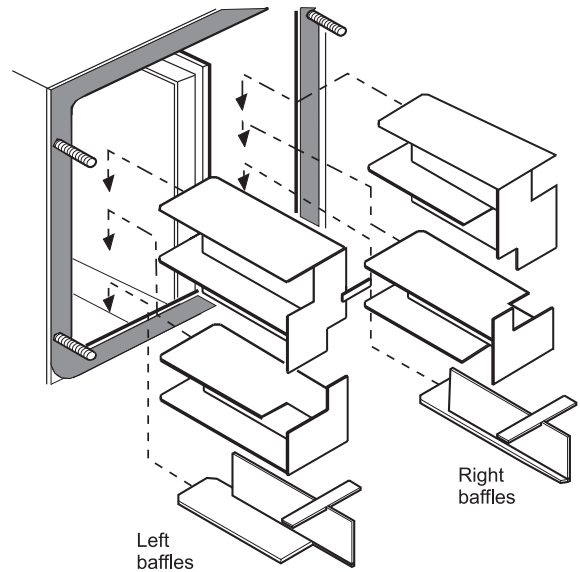

Fig. 25 - 50/90 baffles

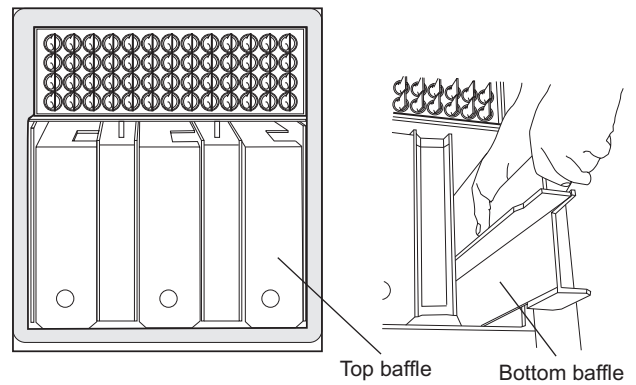

Fig. 27 - 155/200, 200/240 baffles

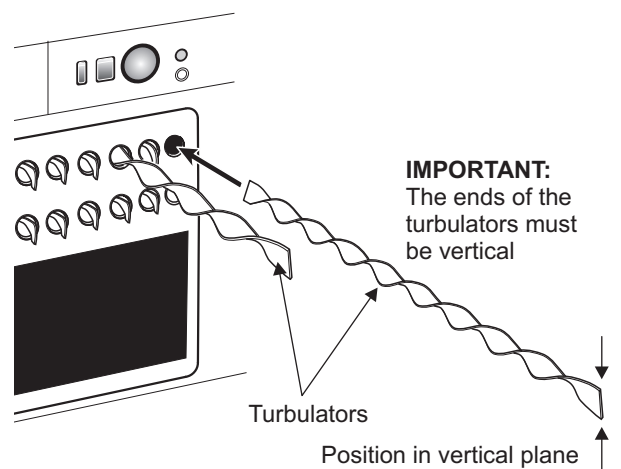

Fig. 28 - Removal/replacement of spiral turbulators (50/90 shown)

9.4 Cleaning the burner

50/70, 70/90, 90/120 and 120/155 - See Section 13

1 **Combustion head** - Loosen the two screws securing the combustion head and withdraw the head. Clean and refit the combustion head.

2 **Inspect the ignition electrodes** - Remove the combustion head.

Loosen the electrode clamp screw and withdraw the electrode assembly. Wipe clean and check for any cracks in the ceramic insulation. Replace if necessary.

Check the electrode settings

Electrode tips approximately 4 mm apart and 3 to 3.5 mm in front of the nozzle, see Fig 29.

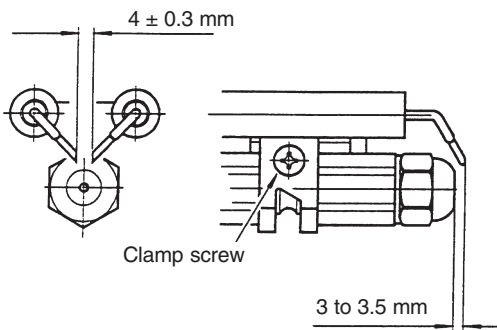

Fig. 29

3 **Nozzle** - The nozzle should be replaced on an annual service - Check that the nozzle size and type are correct, refer to table in Section 3.3 and boiler data label.

With the combustion head removed, loosen the electrode assembly clamp screw and slide the electrodes away from the nozzle.

Do **NOT** attempt to clean the nozzle.

Remove the nozzle using a good fitting spanner (16 mm). The use of an ill-fitting spanner will damage the nozzle and could lead to an incorrect flame pattern. Always check the electrode settings after replacing the nozzle, see Fig. 29.

155/200 or 200/240 models - See Section 13.2 and Fig. 30

1 **Combustion head** - Loosen the two screws securing the combustion head (**NOT** the screws in the slotted ring, Fig. 32) and withdraw the head. Clean and refit the combustion head.

2 **Inspect the ignition electrodes** - Remove the combustion head.

Loosen the electrode clamp screw, disconnect the leads and withdraw the electrode assembly. Wipe clean and check for any cracks in the ceramic insulation. Replace if necessary.

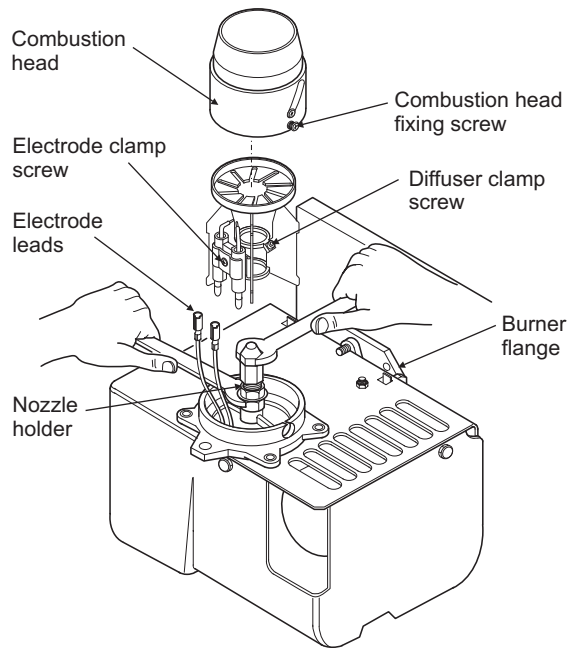

Fig. 30

3 **Check the electrode and diffuser settings** - Fig. 31

To adjust the diffuser disc: Loosen the diffuser clamp screw and slide the disc along the nozzle holder to achieve the gap 'A' in Fig. 31, tighten the screw.

To adjust the electrodes: Loosen the electrode clamp screw and move the electrode unit to achieve the gap 'B' in Fig. 31, tighten the screw.

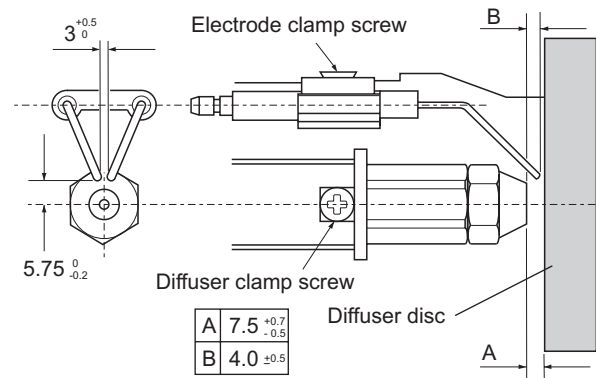

Fig. 31

4 The combustion head position is adjustable on the 155/200 and 200/240 burners. Check that it is fully closed (position 0), or the 4th line if the 200/240 has been set to maximum output (70 kW).

To adjust the head setting, refer to Fig. 32 and proceed as follows: Loosen the two screws in the slotted ring - **NOT** the two fixing screws, and turn the blast tube until '0' lines up with the edge of the slotted ring. Tighten the two screws.

9 - BOILER SERVICING

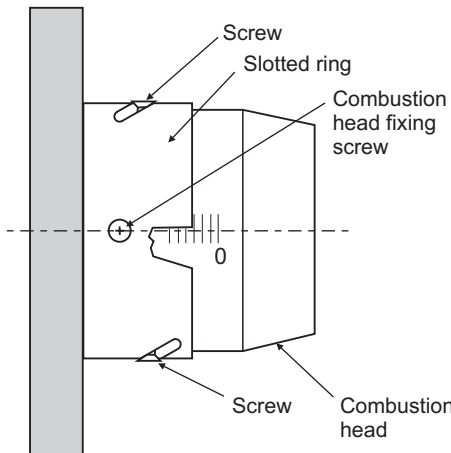

Fig. 32

All models

- Photocell** - The photocell is a push-fit in the burner body. Carefully pull out the photocell to clean.

- Burner fan** - With the air intake grille or spigot removed, remove the screws securing the fan housing cover (R/H side of burner) and remove the cover. Inspect the fan and housing and clean as necessary. Replace the cover.
- Pump filter** - With the burner cover removed, remove the four screws securing the pump end cover. Remove the filter and wash in kerosene. Check for the presence of sludge or water. Replace the filter and end cover, ensure the 'O' ring is in position.

Re-assemble in reverse order.

To ensure safe and efficient operation of the boiler it is important that re-commissioning is carried out, especially combustion checks (CO₂ level, flue gas temperature and smoke number) after the boiler has been serviced.

Refer to the Commissioning instructions starting on page 31.

10 - WIRING DIAGRAM

Vortex External Module wiring diagram

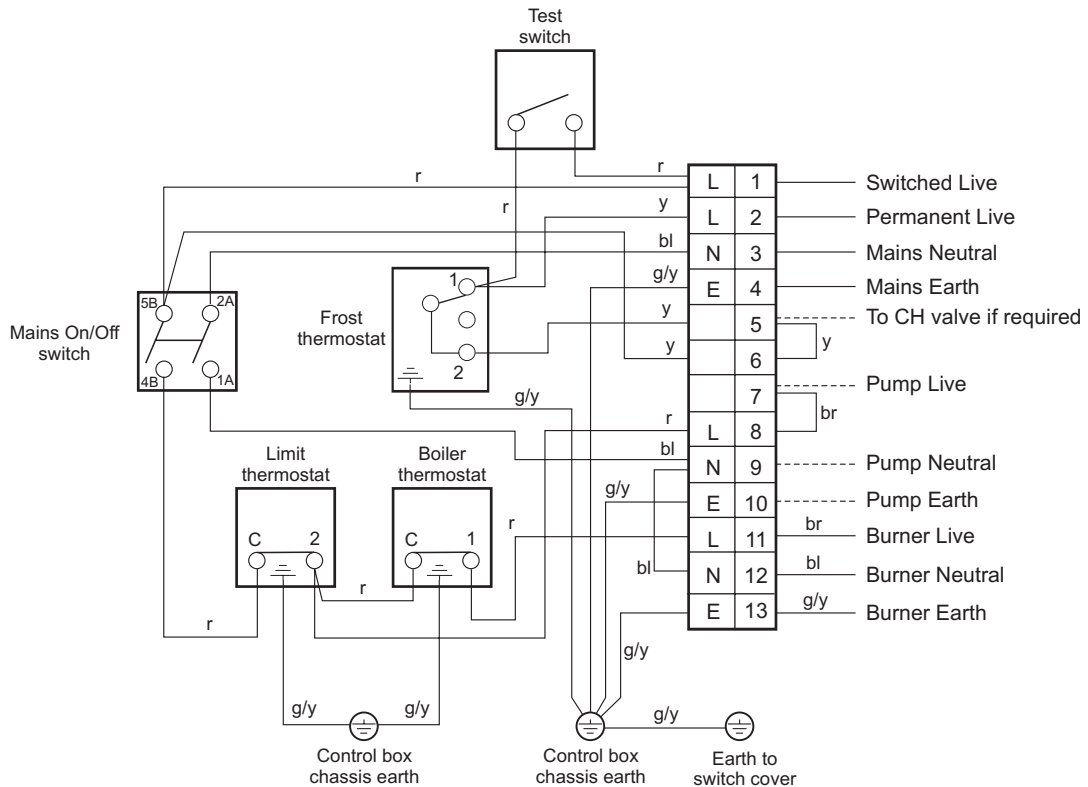

Colour code: br - Brown, r - Red, bl - Blue, y - Yellow, g/y - Green/Yellow

11.1 Burner fault finding

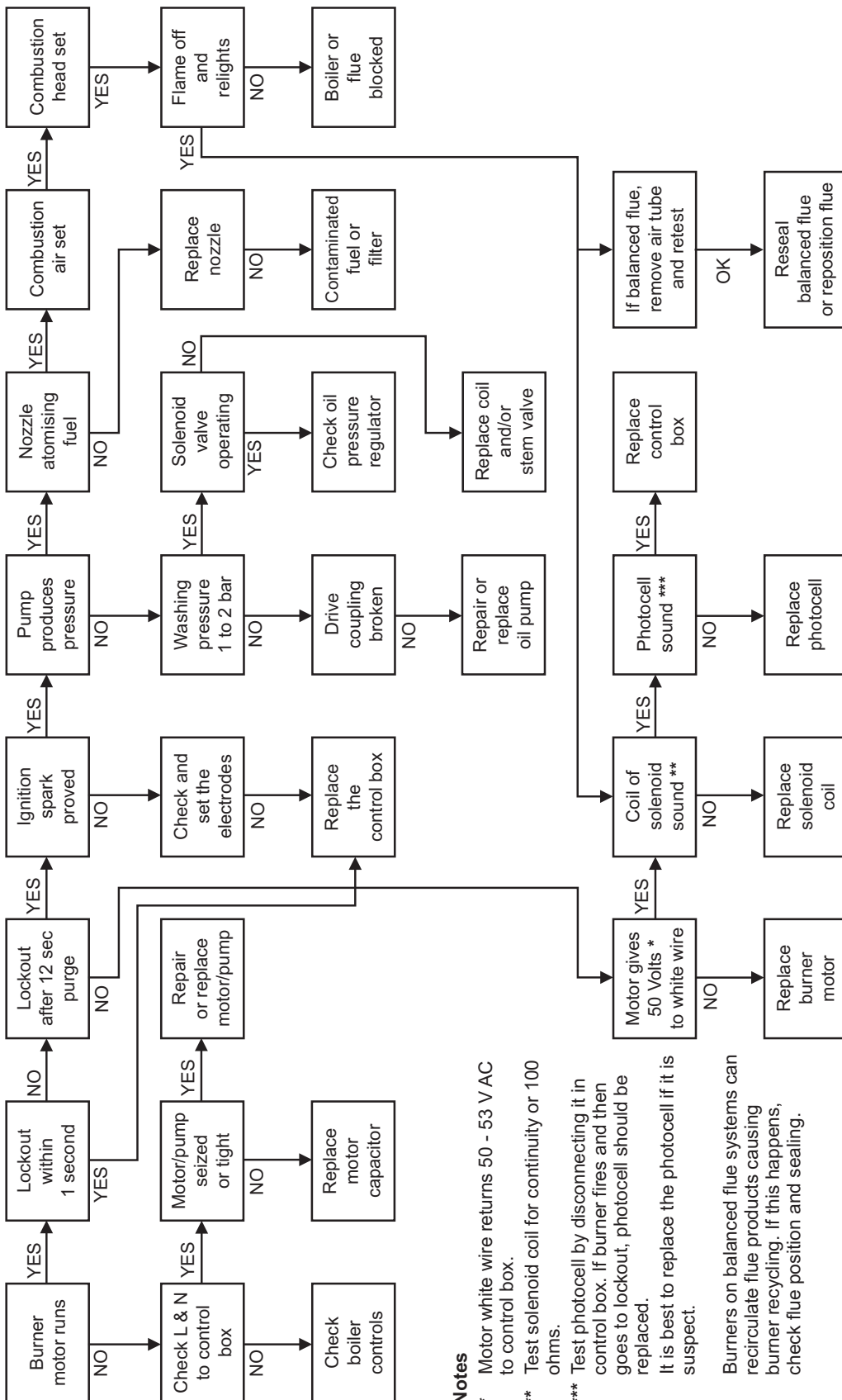

Notes

- * Motor white wire returns 50 - 53 V AC to control box.
 - ** Test solenoid coil for continuity or 100 ohms.
 - *** Test photocell by disconnecting it in control box. If burner fires and then goes to lockout, photocell should be replaced. It is best to replace the photocell if it is suspect.
- Burners on balanced flue systems can recirculate flue products causing burner recycling. If this happens, check flue position and sealing.

11 - FAULT FINDING

11.2 Boiler fault finding

Warning: Always isolate the electricity supply to the boiler before working on the boiler.

Faults

Remedies

Boiler will not start

- | | | |
|---|--|---|
| 1 | No fuel supply. | Ensure that an adequate supply of fuel is available and that the fuel supply valve is open.
Check the condition of the fuel filter, clean if necessary.
Ensure fuel supply is reaching burner and vent pump. |
| 2 | No electricity supply. | Ensure electricity supply to the boiler is switched on and that all controls are calling for heat.
Ensure that the overheat thermostat has not tripped, reset if necessary.
Check that a mains supply is present at the burner terminal block. If not, check the boiler and overheat thermostat. |
| 3 | Burner not starting - fuel and electricity supplies present. | Press the reset button on the burner control box if it is lit.
Refer to burner fault finding flow diagram. |
| 4 | Burner lights but goes to 'lock-out'. | If the flame is unstable, check the combustion settings.
Refer to burner fault finding flow diagram. |

Boiler works but:-

- | | | |
|----|---|--|
| 5 | Visible smoke from flue or high smoke number. | Insufficient air supply - check the air damper setting and the condition of the fan.
Check the nozzle size and type.
Fuel pressure may be too high - check and adjust. |
| 6 | Burner pulsates. | Insufficient air supply - check the air damper setting and the condition of the fan.
Check the nozzle size and type. |
| 7 | Flame slow to stabilise during start up. | Insufficient air supply - check the air damper setting and the condition of the fan.
Check the nozzle size and type.
Fuel pressure may be too low - check and adjust.
Insufficient draught - clean boiler heat exchanger and check condition of flue. |
| 8 | Water temperature low. | Undersize nozzle and/or low fuel pressure.
Check condition of boiler heat exchanger and clean if necessary.
Check the boiler thermostat.
Check the combustion settings.
Check the condition of the fuel filter. |
| 9 | Boiler operating on overheat thermostat. | Faulty boiler thermostat. |
| 10 | Oil odours. | Check all fuel line connections, remake as necessary. |
| 11 | Combustion fumes smell. | Check boiler cleaning cover and seal are correctly fitted.
Check burner is correctly fitted onto flange.
Check flue is correctly sealed into flue outlet of boiler.
Check the condensate pipe and trap are operating correctly. |

12 - BURNER HEADS

Vortex External Module - Burner Heads

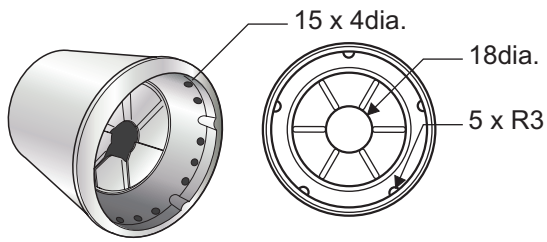

T1 - 50/70, 50/90

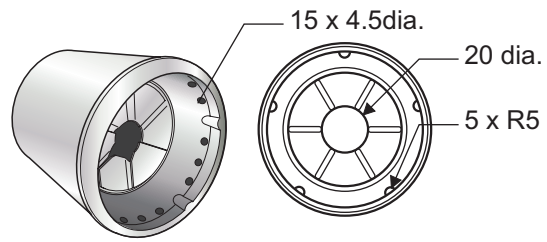

T2 - 50/90

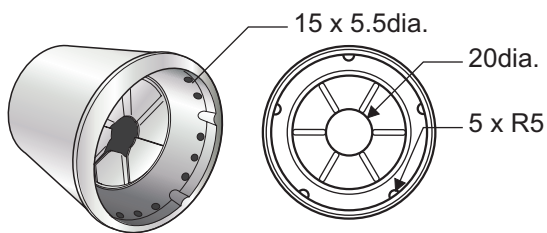

T3 - 90/120, 120/155

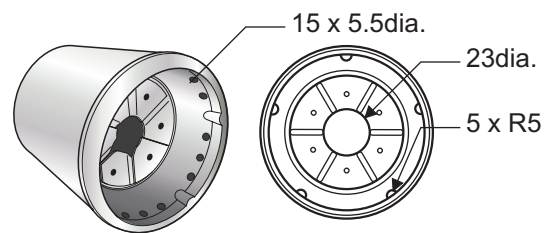

T5 - 120/155

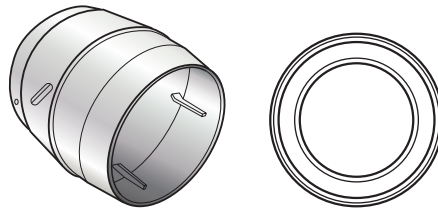

GIB - 155/200, 200/240

13 - BURNER SPARE PARTS

13.1 Riello RDB1, 2, 2.2 burner - exploded view

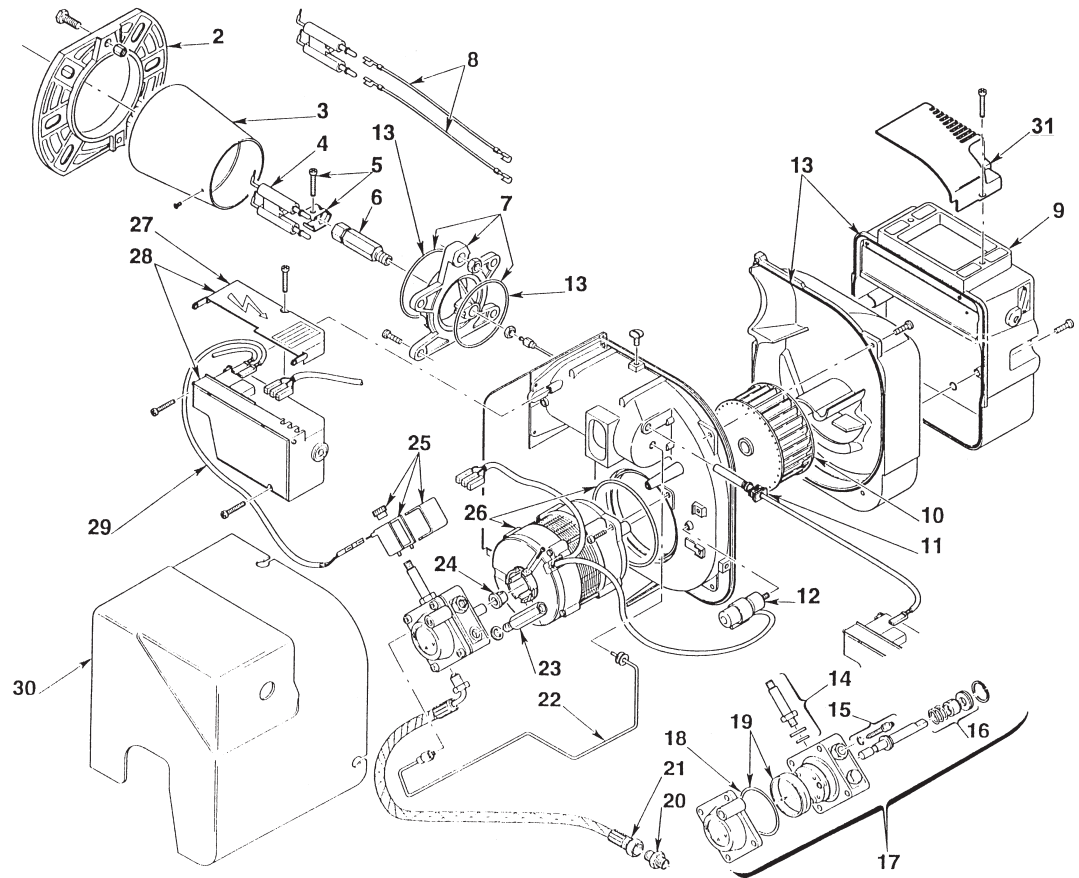

Key No.	Description	Part No.	Key No.	Description	Part No.
1	Not applicable	-	14	Needle valve	3007582
2	Flange	3005786	15	Regulator	3008651
3	Combustion head T1 - 50/70, 50/90	3002507	16	Pump seal	3000439
3	Combustion head T2 - 70/90	3002423	17	Pump	3008654
3	Combustion head T3 - 90/120, 120/155	3002447	18	'O' ring	3007162
3	Combustion head T5 - 120/155	3002533	19	Filter - 'O' ring	3008653
4	Electrode assembly	3007513	20	Connector	3003602
5	Electrode bracket	3006552	21	Flexible pipe	3007672
6	Nozzle holder	3008642	22	Tube	3008644
7	Collar	3008643	23	Pressure gauge connector	3008876
8	High voltage lead	3008794	24	Drive coupling	3000443
9	Air damper assembly	3008647	25	Solenoid	3008648
10	Fan - 50/70	3005708	26	Motor	3002836
10	Fan - 90/120	3008645	27	Cover	3008649
10	Fan - 50/90, 120/155	3005788	28	Control box assembly	3008652
11	Photocell	3008646	29	Solenoid lead	3008851
12	Capacitor 4.5 µF	3002837	30	Cover	3008879
13	Seal kit	3008878	31	Air intake cover	3008649

13 - BURNER SPARE PARTS

13.2 Riello RDB3.2 burner - exploded view

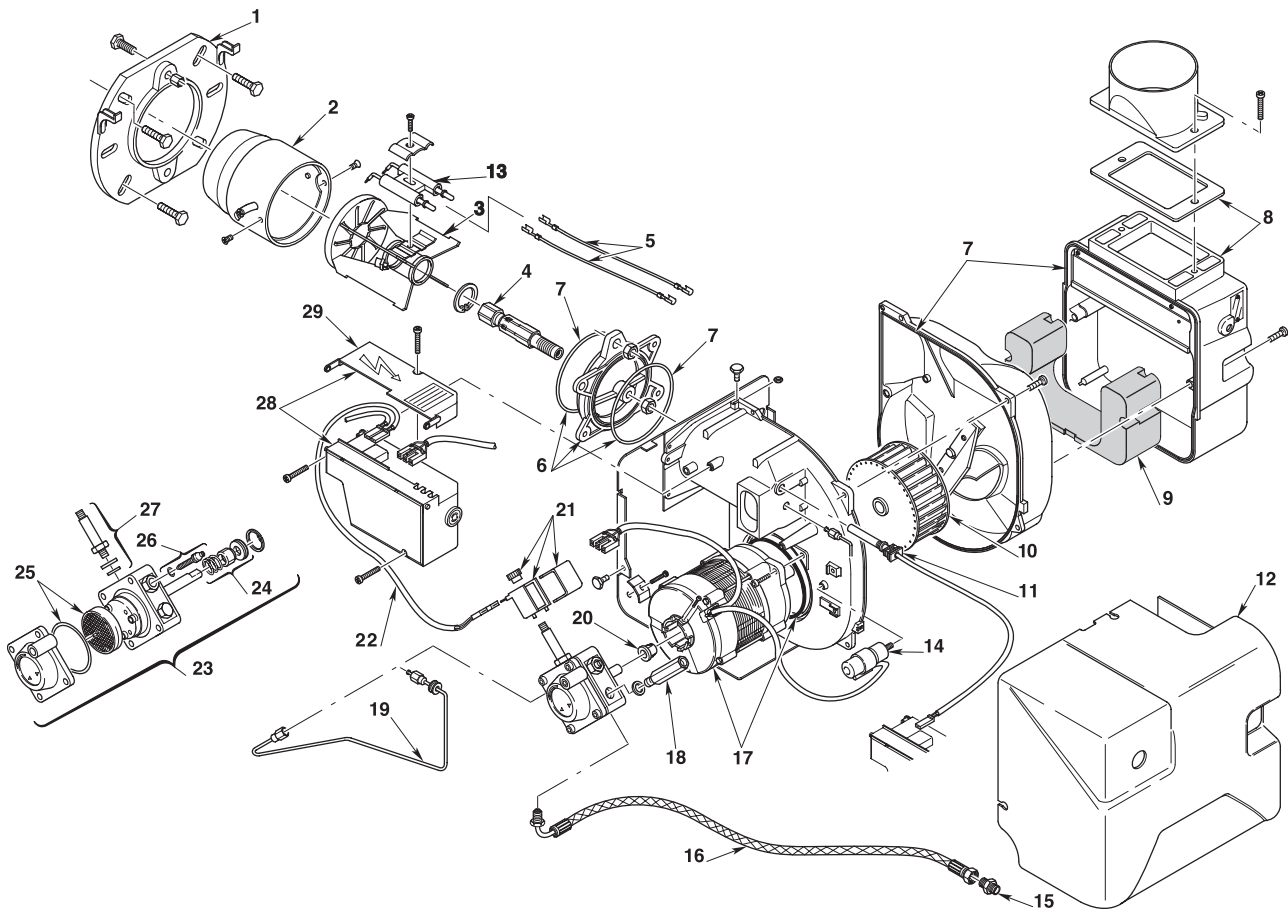

Key No.	Description	Part No.	Key No.	Description	Part No.
1	Flange	3008637	16	Flexible pipe	3005720
2	Combustion head GIB	3002572	17	Motor	3008964
3	Diffuser disc assembly	3020180	18	Pressure gauge connector	3008876
4	Nozzle holder	3002570	19	Tube	3008961
5	High voltage lead	3008794	20	Drive coupling	3000443
6	Collar	3008957	21	Solenoid	3008648
7	Seal kit	3008963	22	Solenoid lead	3008851
8	Air damper assembly	3008839	23	Pump	3008654
9	Insulation	3008958	24	Pump seal	3000439
10	Fan	3005799	25	Filter - 'O' ring	3008653
11	Photocell	3008646	26	Regulator	3008651
12	Cover	3008962	27	Needle valve	3007582
13	Electrode	3020121	28	Control box assembly	3008652
14	Capacitor 5 μ F	3008960	29	Cover	3008649
15	Connector	3003602			

14 - HEALTH AND SAFETY INFORMATION

Under the Consumer Protection Act 1987 and Section 6 of the Health & Safety at Work Act 1974, we are required to provide information on substances hazardous to health (COSHH Regulations 1988).

Adhesives, sealants and paints used in the manufacture of the product are cured and present no known hazards when used in the manner for which they are intended.

The following other materials are present in the product:

Insulation materials

Material Types: Ceramic fibre board, mineral wool.

Description: Rigid board, slabs, sleeves, gaskets, ropes.

Known Hazards: May cause temporary irritation or rash to skin. High dust levels may irritate eyes and upper respiratory system.

Precautions: Avoid unnecessary or rough handling, or harsh abrasion of boards. Normal handling and use of material should not produce high dust levels.
Avoid inhalation, and contact with skin and eyes.
After handling always follow normal good hygiene practices.

Protection: Use disposable gloves, face mask and eye protection.

First Aid: Eyes - If irritation occurs, wash eyes with copious amounts of water. If symptoms persist, seek immediate medical advice.
Skin - If irritation occurs, wash under running water before washing with soap and water.
Inhalation - Remove to fresh air, drink water to clear throat and blow nose to remove dust/fibres.
Ingestion - Drink plenty of water.

Sealants

Material Types: Silicone elastomer.

Description: Sealant and adhesive.

Known Hazards: Irritation to eyes.

Precautions: Avoid inhalation of vapour, contact with eyes and prolonged or repeated contact with skin.
After handling always follow normal good hygiene practices.

Protection: Use eye protection. Rubber or plastic gloves should be worn where repeated contact occurs and a face mask worn when working in confined spaces.

First Aid: Eyes - Flush eyes with water for 15 minutes. Seek immediate medical attention.
Skin - Wipe off and wash with soap and water.
Inhalation - Remove to fresh air.

Kerosene and Gas oil fuels (Mineral oils)

Known Hazards: The effect of mineral oils on the skin vary according to the duration of exposure and the type of oil. The lighter fractions remove the protective grease naturally present on the skin, leaving it dry, liable to crack and more prone to damage by cuts, abrasions and irritant chemicals.
Skin rashes (Oil acne) most often on arms, but also on any part of the body in contact with oil or oily clothing.
Contact with fuel oils can cause dermatitis.

Precautions: Avoid as far as possible any skin contact with mineral oil or with clothing contaminated with mineral oil.
The use of a lanolin-based barrier cream is recommended, in conjunction with regular washing with soap and rinsing with water to ensure all oil is removed from the skin.
Take care to prevent clothing, especially underwear, from becoming contaminated with oil.
Do not put oily rags or tools in pockets, especially trouser pockets.
Have first-aid treatment at once for an injury, however slight.
Do not inhale any vapours from mineral oils.

15 - EC DECLARATION OF CONFORMITY

We declare that the Grant Vortex range of Oil Boilers equipped with Riello RDB burners approved to EN 267: 1991 satisfy the requirements of the following European Directives:-

1. 89/336/EEC - Electromagnetic Compatibility Directive
Referred to the generic standards EN 55014: 1993, EN 50082: 1: 1992
2. 73/23/EEC - Electrical Equipment Safety Regulations Directive
Referred to the generic standard NO: 3260: The Electrical Equipment (Safety) Regulations: 1994
3. 92/42/EEC - Hot Water Boiler Efficiency Directive
Referred to the generic standard The Boiler (Efficiency) (Amendment) Regulations 1994 (SI 1994/3083)

TERMS OF GUARANTEE

1. The Company shall mean Grant Engineering (Ireland) Limited.
2. The Boiler is guaranteed for a period of 12 months from the date of installation, providing that any work undertaken is authorised by the company and carried out by an approved service agent.
3. The shell (heat exchanger) of oil boilers supplied by Grant Engineering (Ireland) Limited are guaranteed for a period of 5 years from the date of installation. All other boiler components, excluding consumables (such as nozzles and filters), for 1 year from the date of installation.
4. This guarantee does not cover breakdowns caused by incorrect installation, neglect, misuse, accident or failure to operate this boiler in accordance with the manufacturers instructions.
5. This guarantee is not transferable unless sanctioned by the Company.
6. The Company will endeavour to provide prompt service in the unlikely event of a problem occurring, but cannot be held responsible for any consequence of delay however caused.
7. This guarantee does not cover labour, handling or shipping.
8. This guarantee applies to boilers installed on the island of Ireland both North and South. Provision for warranty cover elsewhere is subject to agreement with Grant Engineering (Ireland) Limited.



GRANT ENGINEERING (IRELAND) LTD.,
CRINKLE, BIRR, CO. OFFALY.
Telephone: (057) 9120089 / 9120352

This manual is accurate at the date of printing but will be superseded and should be disregarded if specifications and/or appearances are changed in the interests of continued product improvement.

All goods sold are subject to our official Conditions of Sale, a copy of which may be obtained on application.

© Grant Engineering (Ireland) Limited 2010. No part of this manual may be reproduced by any means without prior written consent.