

TRITON

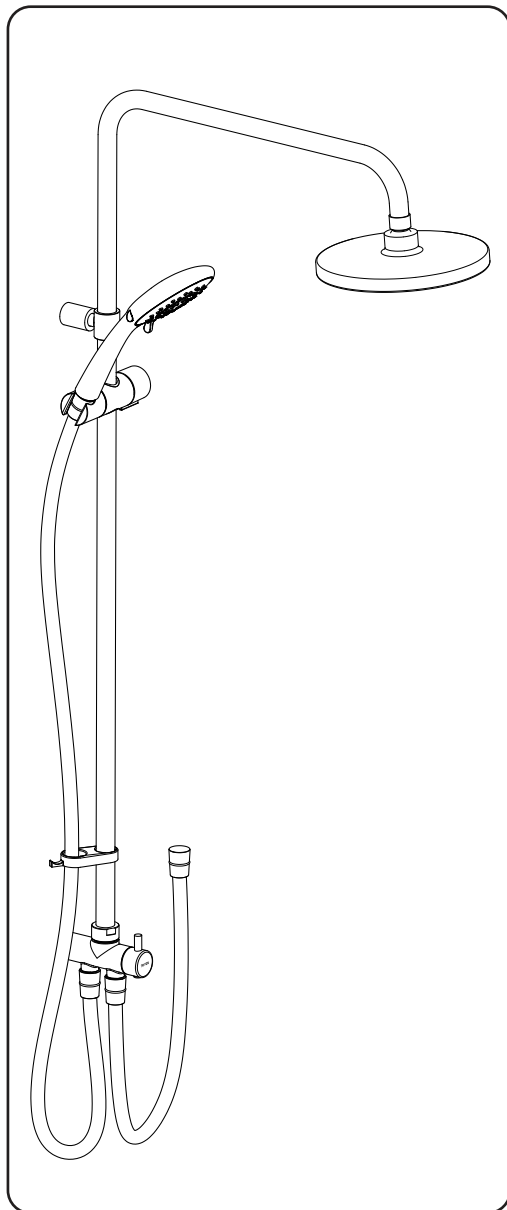

DuElec™

Dual Outlet Diverter Kit for T90SR Pumped Electric Shower

IMPORTANT SAFETY ADVICE

The shower heads and hose supplied with this product are a safety critical part of your shower system. Failure to use genuine Triton parts may cause injury and invalidate your guarantee.

INSTALLATION AND OPERATING INSTRUCTIONS

Please read this book thoroughly and familiarise yourself with all instructions before commencing installation.

Keep these instructions in a safe place for future reference.

MAIN COMPONENTS

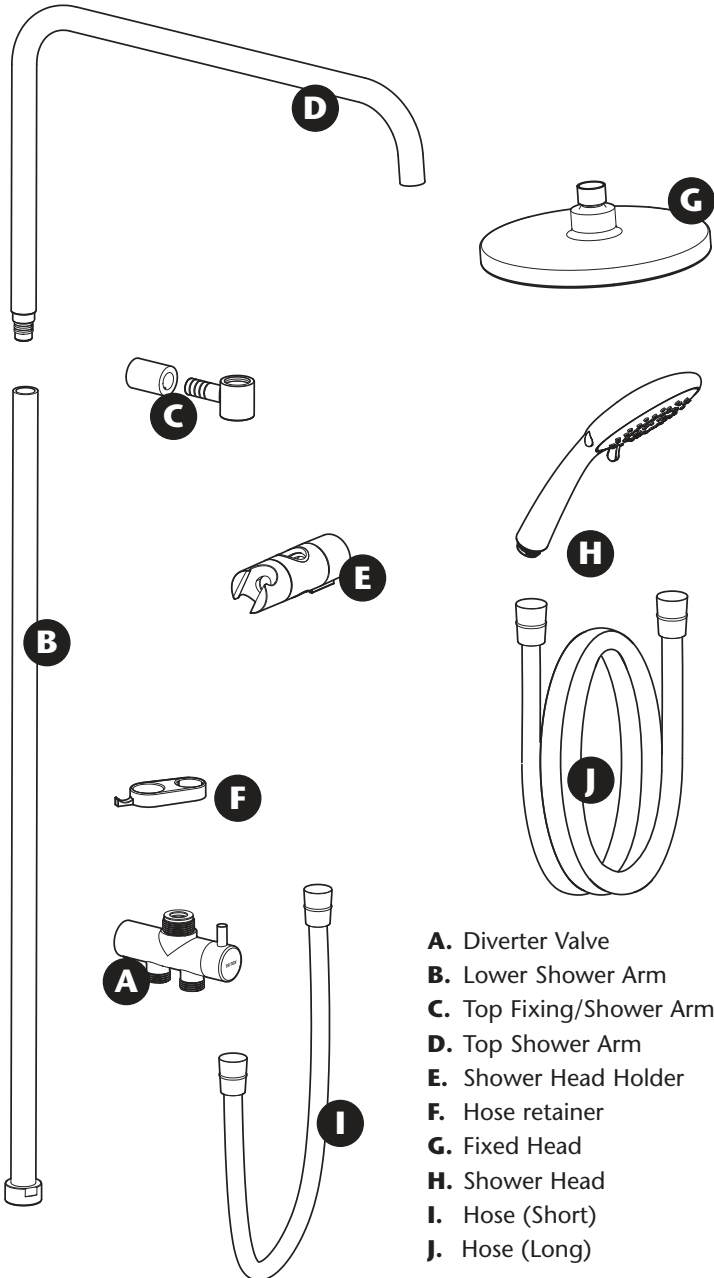

- A.** Diverter Valve
- B.** Lower Shower Arm
- C.** Top Fixing/Shower Arm Holder
- D.** Top Shower Arm
- E.** Shower Head Holder
- F.** Hose retainer
- G.** Fixed Head
- H.** Shower Head
- I.** Hose (Short)
- J.** Hose (Long)

DIMENSIONS

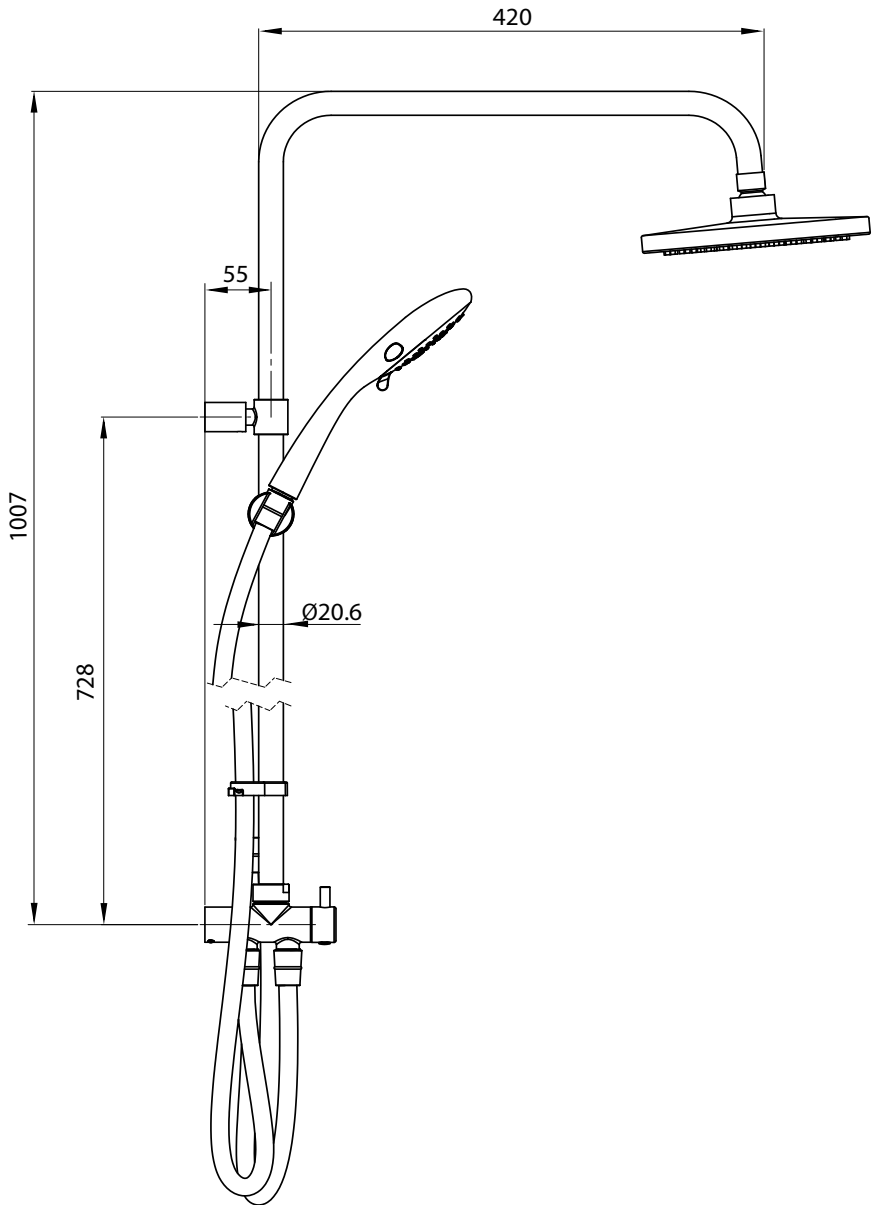

All dimensions are approximate.

INSTALLATION

POSITIONING THE DUAL OUTLET DIVERTER

Ensure that the **Diverter Valve** is mounted within 500mm radius of the shower outlet, this will ensure the **Short Shower Hose** provided is able to connect the electric shower without strains or kinks.

When fitting the **Diverter** to a pumped electric shower, ensure that the **Top Shower Arm** is NOT more than 750mm from the top of the shower unit.

The **Shower Head Holder** can be orientated such that the **Shower Head** can be positioned either side of the Shower Arm.

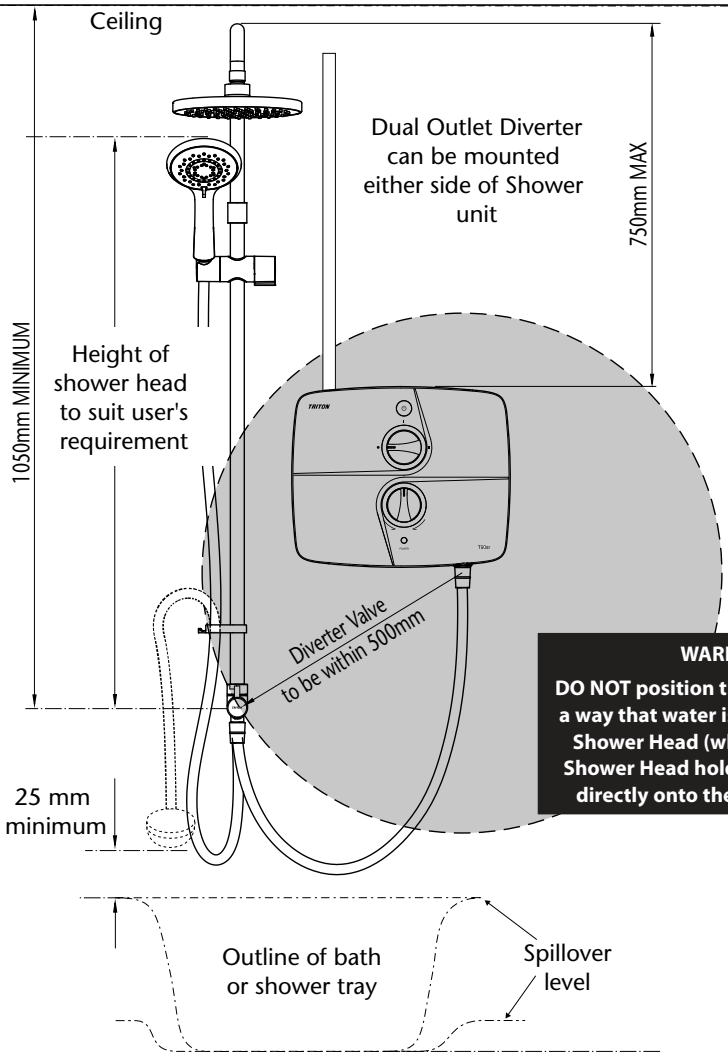

INSTALLATION

Step
1

Always check there are no hidden cables or pipes before drilling holes for wall plugging. Use great care when using power tools near water.

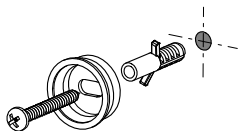

Referring to *Positioning the Dual Outlet Diverter* guidance, mark the wall fixing position for the **Diverter Fixing Bracket** and drill and plug the wall. Ideally the hole should be positioned in the centre of a tile and not in the grouting.

Remove the **Diverter Fixing Bracket** from the **Diverter Valve** and secure it to the wall using the fixing screw.

Step
2

Measure a distance of 728mm from the **Diverter Bracket**, ensuring centres are vertically aligned, and mark the position. Drill and plug the wall. Secure the **Shower Arm Fixing Bracket** to the wall using the fixing screw.

Ensure the **Grub Screw** is pointing downwards.

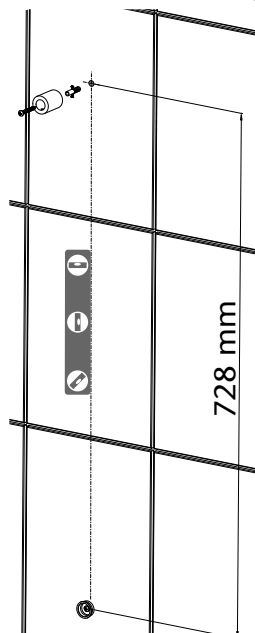

Step
3

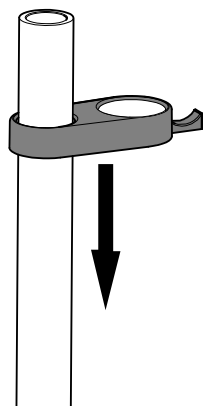

Assemble the **Hose Retainer** onto the **Lower Shower Arm**.

Step
4

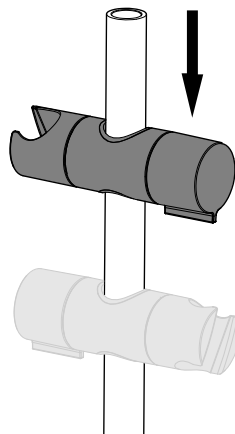

Assemble the **Shower Head Holder** onto the **Lower Shower Arm**.

Note: The **Shower Head Holder** can be orientated such that the **Shower Head** can be positioned either side of the **Shower Arm**.

INSTALLATION

Step
5

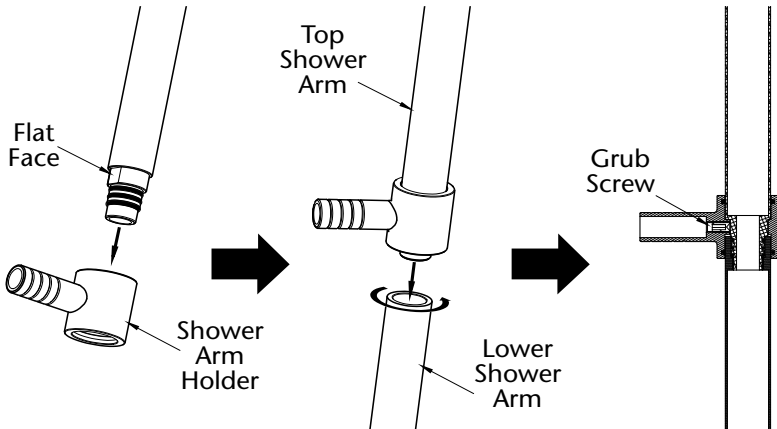

Assemble the **Top Shower Arm** into the **Shower Arm Holder**, note that the **Top Shower Arm** can only be assembled one way, so ensure that the flat faces of **Top Shower Arm** and **Shower Arm Holder** are aligned.

Assemble the **Lower Shower Arm** to **Top Shower Arm** by rotating the **Lower Shower Arm** on to the threaded spigot. Hand tight will be sufficient to seal the two together.

Finally tighten the **Grub Screw** (located inside the bore of the **Shower Arm Holder**) to lock the **Top Shower Arm** to **Shower Arm Holder**.

Step
6

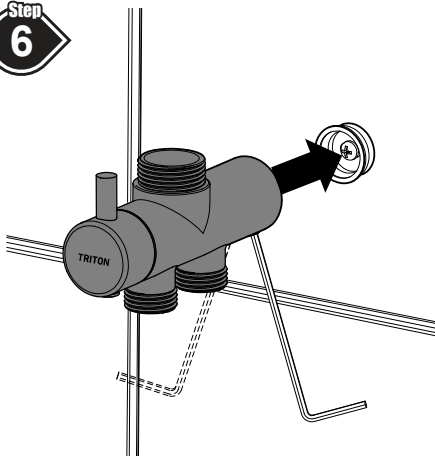

Slide the **Diverter Valve** onto the **Valve Fixing Bracket** and tighten the 2 x **Grub Screws** on the underside of the **Diverter Valve**.

Note: Do not fully tighten the screws as some adjustment of the valve will be necessary when assembling the **Shower Arms**.

Step
7

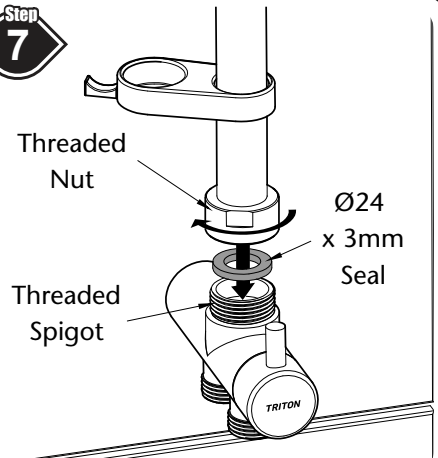

Position the $\text{Ø}24 \times 3\text{mm}$ rubber seal on top of the threaded **Diverter Valve** spigot.

Loosely tighten the threaded nut of the **Lower Shower Arm** onto **Diverter Valve**.

DO NOT fully tighten the threaded nut at this stage.

INSTALLATION

Step

8

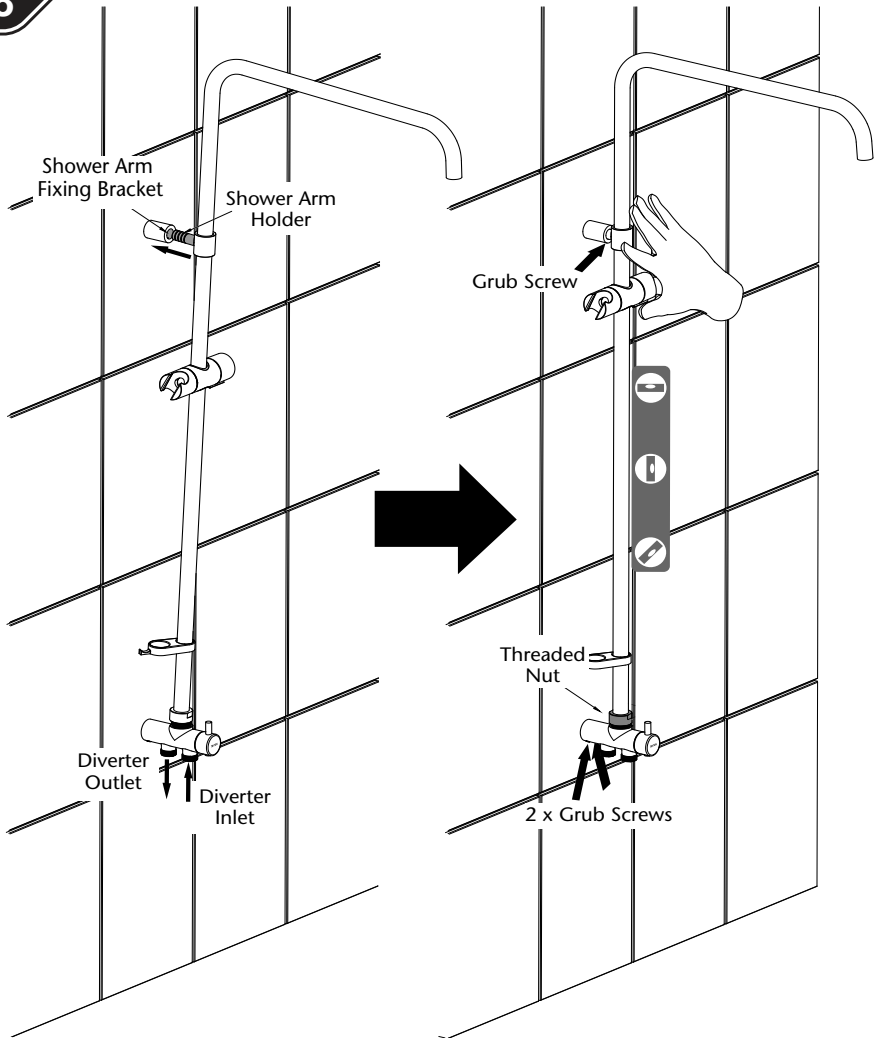

Pivoting the **Shower Arm** slightly away from the wall, slide the stem of the **Shower Arm Holder** into the **Shower Arm Fixing Bracket**.

Holding the **Shower Arms** in place, fully tighten the **Threaded Nut** on the **Diverter Valve**, ensuring that the **Shower Arms** are vertical.

Fully tighten the **Grub screw** in the **Shower Arm Fixing Bracket**, and the 2 x **Grub Screws** on the underside of the **Diverter Valve**.

INSTALLATION

Step
9

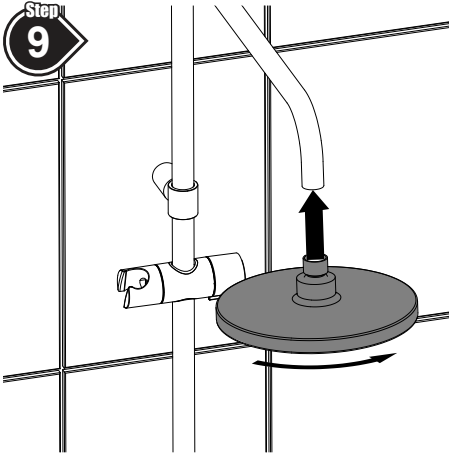

Assemble the **Fixed Head** on to the **Top Shower Arm**.

Step
11

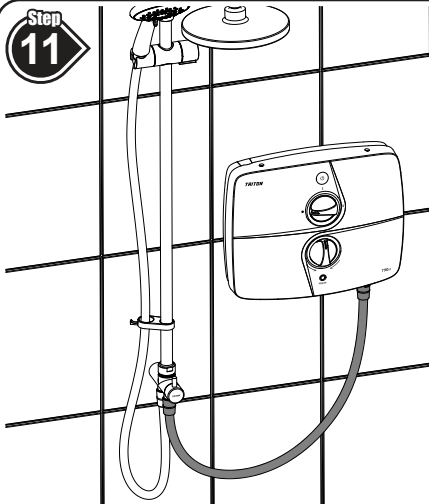

Take the **Short Hose** and fit a hose seal into the conical nut and connect to the **Shower Unit**, fit a hose seal into the conical nut at the other end of the hose and connect to the inlet of the **Diverter Valve**.

Step
10

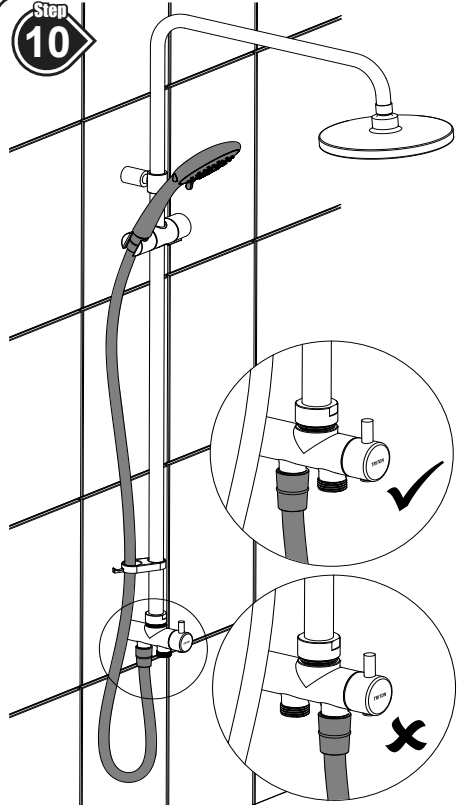

IMPORTANT

Ensure the **Shower Head Hose** is connected to the outlet (back) **Diverter Valve** connector, failure to do this may cause damage to your shower.

Feed your **Triton Long Shower Hose** through the **Hose Retainer**, fit a hose seal into the conical nut and connect to the outlet of the **Diverter Valve**. At the other end of the hose, fit a hose seal into the conical nut and connect to the **Shower Head**.

Place **Shower Head** into the **Shower Head Holder**.

IMPORTANT - Before using the Diverter and Fittings, commission the shower as detailed in the Shower Instructions.

OPERATION

**Position
1**

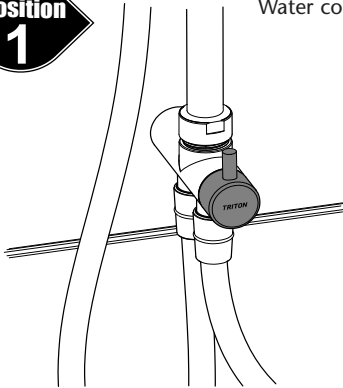

Water comes from the **Fixed Head** only

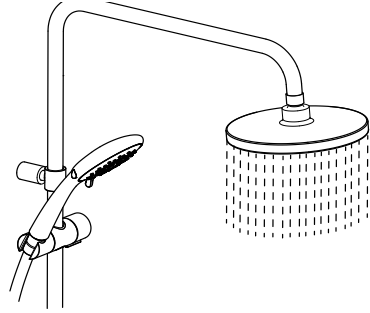

**Position
2**

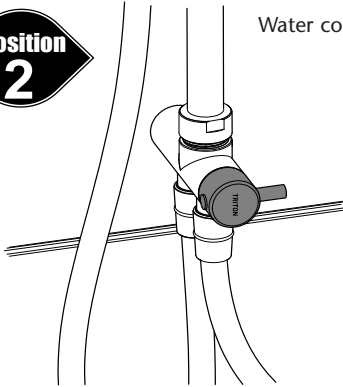

Water comes from the **Fixed Head** and **Shower Head**

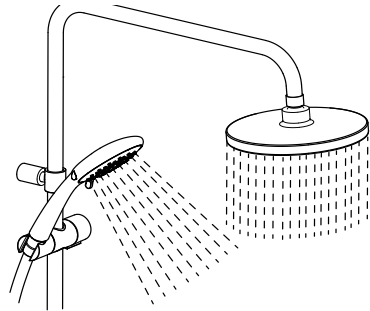

**Position
3**

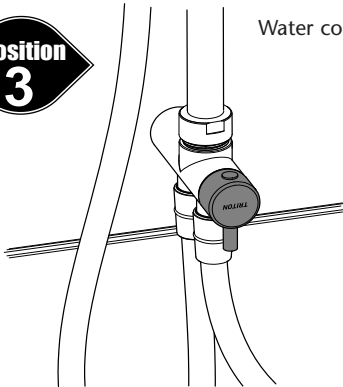

Water comes from the **Shower Head** only

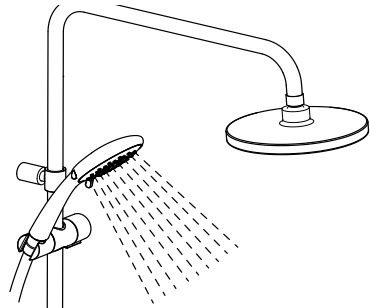

CLEANING

CLEANING THE SHOWER HEAD AND FIXED HEAD

It is important to keep your shower head and fixed head clean to maintain the performance of your shower.

Triton recommends that all products are cleaned using warm, soapy water.

DO NOT use abrasive or aggressive chemical cleaning products as this may affect the product surface and finish and invalidate your guarantee.

Both the shower head and fixed head can be cleaned quickly by simply rubbing your fingers over the spray plate. **DO NOT** use a pin or similar to poke the holes otherwise the efficiency of the shower spray will be impaired.

The hardness of the water will determine the frequency of cleaning. For example, if the shower is used every day in a very hard water area, it may be necessary to clean the shower head on a weekly basis.

INSPECTING THE HOSES

Your shower hoses should be inspected from time to time for signs of damage or internal collapse. Internal collapse can restrict the flow rate from the shower head and may cause damage to the shower.

Triton recommends use of a Triton branded anti-twist hose on all showers to ensure continuous safe performance.

To inspect your hose:

1. Unscrew the hose from the shower head and the diverter outlet.
2. Inspect the hose for damage, internal kinks, etc.
3. If necessary, replace the hose.

SERVICE POLICY

In the event of a product fault or complaint occurring, the following procedure should be followed:

DO NOT REMOVE THE PRODUCT

1. Telephone Customer Service on **01 628 6711** or **01 628 6845** having available your details including post code, the model number and power rating of the product, together with the date of purchase and, where applicable, details of the particular fault.
2. If required, the Customer Service Advisor will arrange for a qualified engineer to call.
3. All products attended to by a Triton service engineer must be installed in full accordance with the Triton installation guide applicable to the product. Every product pack contains an installation guide, however, they can also be downloaded free at www.tritonshowers.ie.
4. Our engineer will require local parking and if a permit is required, this must be available to the engineer on arrival at the call.
5. If loft access is required for isolation or to complete a repair, the loft must have a fixed access ladder and be boarded, with appropriate lighting from the access point to and around the repair area.
6. It is essential that you or an appointed representative, who must be over 18 years of age, is present for the duration of the service engineer's visit. If the product is in guarantee you must produce proof of purchase.
7. Where a call under the terms of guarantee has been booked and the failure is not product related (i.e. scaling and furring, incorrect water pressure, pressure relief device operation or electrical/plumbing installation fault) a charge will be made. A charge will also be issued if nobody is at home when the service engineer calls or adequate parking/permit is not available.
8. If the product is no longer covered by the guarantee an up-front fixed fee will be charged before the site visit.
9. Your receipt must be retained as proof of purchase. Should proof of purchase not be available on an 'in-guarantee' call, or should the service engineer find that the product is no longer under guarantee, the engineer will charge the same fixed price and will request payment prior to departing. If payment is not made on the day an administration charge will be added to the fixed charge.
10. If a debt is outstanding from a previous visit, or from any other Triton purchase, Triton reserves the right to withhold service until the debt has been settled.
11. Triton takes the health, safety and wellbeing of its employees very seriously and expects customers to treat all staff members with respect. Should any employee feel threatened or receive abuse, either verbally or physically, Triton reserves the right to withhold service.

Replacement Parts Policy

In line with AMDEA guidelines, Triton retains functional spares for as long as there is a market for them and in most cases, well beyond. Due to the vast array of product types, the life cycle of products can vary and therefore so can the length of time parts can be supplied. Spare parts can be ordered via our online spare parts store or by telephoning Triton Customer Service Spares Department on **01 628 6711**. Payment should be made by credit / debit card (excluding American Express or Diners Card). Payment can also be made by pre-payment of a pro-forma invoice, by cheque or postal order.

Telephone orders are based on information given during the call. Before contacting Triton, please verify your requirements using the Information contained in the user guide. Triton cannot accept liability for incorrect part identification.

Eartridge International Ltd
Maynooth
Co. Kildare.

TRITON STANDARD GUARANTEE

With the exception of accessories, Triton guarantee the product against all manufacturing defects for a period of **2 years** (for domestic use only) from the date of purchase, provided that it has been installed by a competent person in full accordance with the fitting instructions.

All accessories such as shower heads, hoses and riser rails carry a **1 year** parts only guarantee against manufacturing defects.

Any part found to be defective during this guarantee period we undertake to repair or replace at our option without charge, so long as it has been properly maintained and operated in accordance with the operating instructions and has not been subject to misuse or damage. This product must not be taken apart, modified or repaired except by a person authorised by Triton. This guarantee applies only to products installed within the Republic of Ireland and does not apply to products used commercially. This guarantee does not affect your statutory rights.

What is not covered:

1. Breakdown due to:
 - a) use other than domestic use by the property occupants;
 - b) wilful act or neglect;
 - c) any malfunction resulting from the incorrect use or quality of electricity, gas or water or incorrect setting of controls;
 - d) failure to install in accordance with this installation guide.
2. Claims for missing parts once the product has been installed.
3. Repair costs for damage caused by foreign objects or substances.
4. Total loss of the product due to non-availability of parts.
5. Compensation for loss of use of the product or consequential loss of any kind.
6. Call out charges due to an abortive visit or where no fault has been found with the appliance.
7. The cost of repair or replacement of isolating switches, electrical cable, fuses and/or circuit breakers or any other accessories installed at the same time. Replacement of the Pressure Relief Device that only activates when the shower outlet is blocked is also excluded.
8. The cost of routine maintenance, adjustments, overhaul modifications or loss or damage arising therefrom, including the cost of repairing damage, breakdown, malfunction caused by corrosion, furring, frost or exposure to freezing conditions.
9. Call out charges where the water supply cannot be isolated, this includes consequential losses arising from unserviceable supply valves, or inaccessible product or valves located in a loft space without suitable access.

For the latest Terms & Conditions please see:

www.tritonshowers.ie/terms

Triton Showers
Triton Road
Nuneaton
Warwickshire, CV11 4NR

Triton is a division of Norcros Group (Holdings) Limited

TRITON reserve the right to change product specification without prior notice. E&OE. © TRITON SHOWERS 2022