

# Secura Lite

mortar-free retaining wall

- Easy to build
- Used mainly in domestic applications
- Features a unique aged finish
- Available in a combination of three block widths
- Creates a random stone appearance
- Vibrant long-lasting colours

## product specifications

<b>Product type</b>	Concrete Block
<b>Manufactured to</b>	BS EN 771-3:2011
<b>Surface Finish</b>	Processed to give aged antique appearance
<b>Efflorescence</b>	Minimum 12 hour vapour curing to significantly reduce the possibility of efflorescence
<b>Strength</b>	Typical tensile splitting strength of >30N/mm <sup>2</sup>
<b>Design and Installation to</b>	BS 8002:2015
<b>BS</b>	<b>Plus:</b> D41 310 <b>Create:</b> 45-25-66/320
<b>Applications</b>	Low height gravity retaining wall solution for walls up to a maximum of 960mm high. Please refer to Tobermore's Secura Lite installation guidelines.
<b>Energy used</b>	100% renewable energy
<b>Water used</b>	100% from our rainwater harvesting system and groundwater bore hole
<b>Recycled content</b>	Not less than 6%
<b>Carbon Footprint</b>	1.6kgCo <sub>2</sub> e/ea
<b>Recyclable</b>	100% of this product can be recycled
<b>Manufacturing &amp; Delivery</b>	From one location within the UK
<b>breedon rating</b> www.bre.co.uk	Refer to the Green Guide to Specification, 4 <sup>th</sup> Edition 2009.

Tobermore products are manufactured in accordance with an accredited ISO 9001:2015 quality system. Manufacturing facilities are accredited to ISO14001:2015 Environmental Management. The company publish environmental labels and declarations in accordance with BS EN ISO 14021:2016 and BES 6001.

## colours

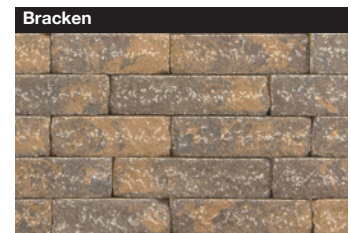
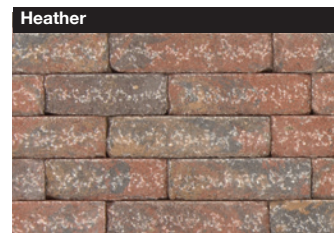

**Important Information**  
Secura Lite can be built to a maximum height of 960mm.



Secura Lite Bracken



## product profile

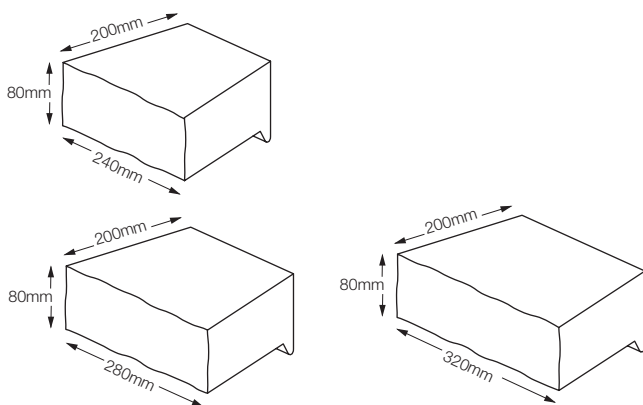

product	size (mm)	colours available	in stock	LM per pack	LM per slice	no. per m <sup>2</sup>	no. per pack	weight (kg) per pack
SECURA LITE (all three sizes in one pack)	320 x 200 x 80	Bracken, Heather, Slate	YES	33.6	0.84	44.64	40	1121
	280 x 200 x 80						40	
	240 x 200 x 80						40	
SECURA LITE COPING	310/255 x 240 x 70 (tapered coping)	Bracken, Heather, Slate	YES	-	-	3.5 LM	120	1316

Refer to all instructions and warnings on our website