

## Xtratherm Limited

Kells Road  
Navan  
Co Meath, Ireland  
Tel: 00 353 46 9066000 Fax: 00 353 46 9066090  
e-mail: info@xtratherm.com  
website: www.xtratherm.com



Agrément Certificate  
**04/4130**  
Product Sheet 4

### XTRATHERM THIN-R INSULATION

### XTRATHERM THIN-R UNDERFLOOR BOARD (XT/UF)

This Agrément Certificate Product Sheet<sup>(1)</sup> relates to Xtratherm Thin-R Underfloor Board (XT/UF), comprising rigid polyisocyanurate foam boards with a composite foil-facing on both sides, for use on ground-supported or suspended concrete ground floors or between the joists of suspended timber ground floors in new and existing dwellings.

(1) Hereinafter referred to as 'Certificate'.

#### CERTIFICATION INCLUDES:

- factors relating to compliance with Building Regulations where applicable
- factors relating to additional non-regulatory information where applicable
- independently verified technical specification
- assessment criteria and technical investigations
- design considerations
- installation guidance
- regular surveillance of production
- formal three-yearly review.

#### KEY FACTORS ASSESSED

**Thermal performance** — the product has a thermal conductivity\* ( $\lambda_D$  value) of  $0.022 \text{ W}\cdot\text{m}^{-1}\cdot\text{K}^{-1}$  (see section 6).

**Condensation** — the product can adequately limit the risk of surface condensation on floors (see section 7).

**Floor loading** — the product, when covered with a suitable overlay as specified in section 4.5, can support a design loading without undue compression deflection (see section 9).

**Durability** — the product, when installed with the overlays specified, will remain effective as an insulating material for the life of the building in which it is incorporated (see section 11).

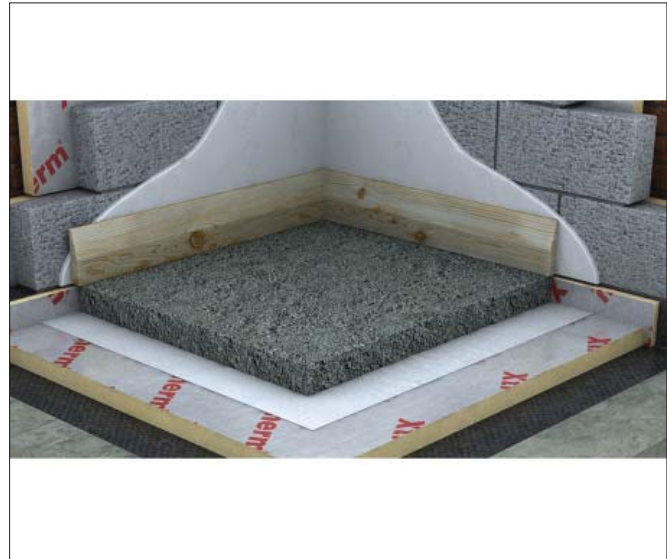

The BBA has awarded this Certificate to the company named above for the product described herein. This product has been assessed by the BBA as being fit for its intended use provided it is installed, used and maintained as set out in this Certificate.

On behalf of the British Board of Agrément

A handwritten signature in black ink, appearing to read 'John Albon'.

Date of First issue: 30 September 2013

John Albon — Head of Approvals  
Energy and Ventilation

A handwritten signature in black ink, appearing to read 'Claire Curtis-Thomas'.

Claire Curtis-Thomas  
Chief Executive

*The BBA is a UKAS accredited certification body — Number 113. The schedule of the current scope of accreditation for product certification is available in pdf format via the UKAS link on the BBA website at [www.bbacerts.co.uk](http://www.bbacerts.co.uk)*

*Readers are advised to check the validity and latest issue number of this Agrément Certificate by either referring to the BBA website or contacting the BBA direct.*

British Board of Agrément  
Bucknalls Lane  
Watford  
Herts WD25 9BA

©2013

tel: 01923 665300  
fax: 01923 665301  
e-mail: [mail@bba.star.co.uk](mailto:mail@bba.star.co.uk)  
website: [www.bbacerts.co.uk](http://www.bbacerts.co.uk)

# Regulations

In the opinion of the BBA Xtratherm Thin-R Underfloor Board (XT/UF), if installed, used and maintained in accordance with this Certificate, will meet or contribute to meeting the relevant requirements of the following Building Regulations (the presence of a UK map indicates that the subject is related to the Building Regulations in the region or regions of the UK depicted):



## The Building Regulations 2010 (England and Wales) (as amended)

<b>Requirement:</b>	A1	<b>Loading</b>
<b>Comment:</b>		The product has adequate strength and stiffness. See section 9.2 of this Certificate.
<b>Requirement:</b>	C2(c)	<b>Resistance to moisture</b>
<b>Comment:</b>		The product can adequately limit the risk of surface condensation. See sections 7.1 and 7.5 of this Certificate.
<b>Requirement:</b>	L1(a)(i)	<b>Conservation of fuel and power</b>
<b>Comment:</b>		The product can contribute to satisfying this Requirement. See sections 6.1 and 6.2 of this Certificate.
<b>Regulation:</b>	7	<b>Materials and workmanship</b>
<b>Comment:</b>		The product is acceptable. See section 11 and the <i>Installation</i> part of this Certificate.
<b>Regulation:</b>	26	<b>CO<sub>2</sub> emission rates for new buildings</b>
<b>Comment:</b>		The product can contribute to satisfying this Regulation. See sections 6.1 and 6.2 of this Certificate.



## The Building (Scotland) Regulations 2004 (as amended)

<b>Regulation:</b>	8(1)	<b>Durability, workmanship and fitness of materials</b>
<b>Comment:</b>		The product can contribute to a construction satisfying this Regulation. See section 11 and the <i>Installation</i> part of this Certificate.
<b>Regulation:</b>	9	<b>Building standards applicable to construction</b>
<b>Standard:</b>	1.1(a)(b)	<b>Structure</b>
<b>Comment:</b>		The product has adequate strength and stiffness, with reference to clause 1.1.1 <sup>(1)</sup> . See section 9.2 of this Certificate.
<b>Standard:</b>	3.15	<b>Condensation</b>
<b>Comment:</b>		The product can adequately limit the risk of surface condensation, with reference to clauses 3.15.1 <sup>(1)</sup> , 3.15.4 <sup>(1)</sup> and 3.15.5 <sup>(1)</sup> . See sections 7.1 and 7.6 of this Certificate.
<b>Standard:</b>	6.1(b)	<b>Carbon dioxide emissions</b>
<b>Standard:</b>	6.2	<b>Building insulation envelope</b>
<b>Comment:</b>		The product can contribute to satisfying clauses, or parts of, 6.1.2 <sup>(1)</sup> , 6.1.6 <sup>(1)</sup> , 6.2.1 <sup>(1)</sup> , 6.2.7 <sup>(1)</sup> , 6.2.9 <sup>(1)</sup> , 6.2.11 <sup>(1)</sup> and 6.2.13 <sup>(1)</sup> of these Standards. See sections 6.1 and 6.2 of this Certificate.
<b>Standard:</b>	7.1(a)(b)	<b>Statement of sustainability</b>
<b>Comment:</b>		The product can contribute to satisfying the relevant requirements of Regulation 9, Standards 1 to 6, and, therefore will contribute to a construction meeting a bronze level of sustainability as defined in this Standard. In addition, the product can contribute to a construction meeting a higher level of sustainability as defined in this Standard, with reference to clauses 7.1.4 <sup>(1)</sup> [Aspects 1 <sup>(1)</sup> and 2 <sup>(1)</sup> ], 7.1.6 <sup>(1)</sup> [Aspects 1 <sup>(1)</sup> and 2 <sup>(1)</sup> ] and 7.1.7 <sup>(1)</sup> [Aspect 1 <sup>(1)</sup> ]. See section 6.1 of this Certificate.
<b>Regulation:</b>	12	<b>Building standards applicable to conversions</b>
<b>Comment:</b>		Comments made in relation to this product under Regulation 9, Standards 1 to 6, also apply to this Regulation, with reference to clause 0.12.1 <sup>(1)</sup> and Schedule 6 <sup>(1)</sup> . (1) Technical Handbook (Domestic).



## The Building Regulations (Northern Ireland) 2012

<b>Regulation:</b>	23	<b>Fitness of materials and workmanship</b>
<b>Comment:</b>		The product is acceptable. See section 11 and the <i>Installation</i> part of this Certificate.
<b>Regulation:</b>	29	<b>Condensation</b>
<b>Comment:</b>		The product can adequately limit the risk of surface condensation. See section 7.1 of this Certificate.
<b>Regulation:</b>	30	<b>Stability</b>
<b>Comment:</b>		The product has adequate strength and stiffness. See section 9.2 of this Certificate.
<b>Regulation:</b>	39(a)(i)	<b>Conservation measures</b>
<b>Regulation:</b>	40(2)	<b>Target carbon dioxide emission rate</b>
<b>Comment:</b>		Floors incorporating the product can contribute to satisfying these Regulations. See sections 6.1 and 6.2 of this Certificate.

## Construction (Design and Management) Regulations 2007

## Construction (Design and Management) Regulations (Northern Ireland) 2007

Information in this Certificate may assist the client, CDM co-ordinator, designer and contractors to address their obligations under these Regulations.

See section: 3 *Delivery and site handling* (3.3) of this Certificate.

## Additional Information

### NHBC Standards 2013

NHBC accepts the use of Xtratherm Thin-R Underfloor Board (XT/UF), provided it is installed, used and maintained in accordance with this Certificate, in relation to *NHBC Standards*, Chapter 5.1, *Substructure and ground bearing floors*.

### CE marking

The Certificate holder has taken the responsibility of CE marking the product, in accordance with harmonised European Standard BS EN 13165 : 2012. An asterisk (\*) appearing in this Certificate indicates that data shown is given in the manufacturer's Declaration of Performance.

## Technical Specification

### 1 Description

1.1 Xtratherm Thin-R Underfloor Board (XT/UF) comprises rigid polyisocyanurate foam, with a composite foil-facing on both sides.

1.2 The boards have the nominal characteristics shown in Table 1.

Table 1 Nominal characteristics

Length (mm)	2400
Width (mm)	1200
Thickness* (mm)	25 to 165
Minimum compressive strength* at 10% compression (kPa)	140
Edge profile	plain

1.3 Ancillary items used with the product, but outside the scope of this Certificate, are:

- saddle clips
- galvanized nails
- pre-treated battens
- acrylic adhesive foil tape
- damp-proof membrane (dpm)
- vapour control layer (VCL).

### 2 Manufacture

2.1 Raw materials are injected onto the lower foil-facer on a conveyor belt. The exothermic reaction expands the foam, which then comes into contact with the upper foil-facer. An automated process cures and cuts the product to the required size.

2.2 As part of the assessment and ongoing surveillance of product quality, the BBA has:

- agreed with the manufacturer the quality control procedures and product testing to be undertaken
- assessed and agreed the quality control operated over batches of incoming materials
- monitored the production process and verified that it is in accordance with the documented process
- evaluated the process for management of nonconformities
- checked that equipment has been properly tested and calibrated
- undertaken to carry out the above measures on a regular basis through a surveillance process, to verify that the specifications and quality control operated by the manufacturer are being maintained.

2.3 The management system of Xtratherm Limited has been assessed and registered as meeting the requirements of BS EN ISO 9001 : 2008 by Loss Prevention Certification Board (Certificate 851).

### 3 Delivery and site handling

3.1 The product is delivered to site in polythene shrink-wrapped packs containing a label bearing the manufacturer's trade name, product description, and the BBA identification mark incorporating the number of this Certificate.

3.2 It is essential that the product is stored raised off the ground, inside or under cover on a flat, dry, level surface in a well-ventilated area. The product must be protected from rain, snow and prolonged exposure to sunlight. Boards that have been allowed to get wet or that are damaged must not be used. Nothing should be stored on top of boards.

3.3 The product must not be exposed to a naked flame or other ignition sources. The product must not be exposed to solvents or other chemicals.

# Assessment and Technical Investigations

The following is a summary of the assessment and technical investigations carried out on Xtratherm Thin-R Underfloor Board (XT/UF).

## Design Considerations

### 4 General

4.1 Xtratherm Thin-R Underfloor Board (XT/UF) is for use on ground-supported or suspended concrete ground floors or between the joists of suspended timber ground floors, in new and existing dwellings, as detailed in Figures 1 to 8.

4.2 The product is effective in reducing the thermal transmittance (U value) of new or existing ground floors.

4.3 Ground-supported concrete and suspended ground floors incorporating the insulation must include a suitable dpm laid in accordance with the relevant clauses of CP 102 : 1973, BS 8102 : 2009 and/or BS 8215 : 1991 or suitable ventilation of the sub-floor as appropriate.

4.4 Suspended concrete or timber ground-floors incorporating the product must include a dpm or suitable ventilation of the sub-floor as appropriate.

4.5 The overlay (suitable floors) to the product should be a:

- cement-based floor screed laid in accordance with the relevant clauses of BS 8204-1 : 2003 and/or BS 8204-2 : 2003, and BS 8000-9 : 2003, or
- wood-based floor, eg tongue-and-groove, flooring grade particle board (Type P4 to P7) to BS EN 312 : 2010 or oriented strand board of type OSB/2 to OSB/4 to BS EN 300 : 2006, 18 mm thick (minimum), installed in accordance with DD CEN/TS 12872 : 2007 and BS EN 12871 : 2010, or
- concrete slab to BS EN 1992-1-1 : 2004.

### 5 Practicability of installation

The product is designed to be installed by a competent general builder, or a contractor, experienced with this type of product.

### 6 Thermal Performance

6.1 Calculations of the thermal transmittance (U value) of a floor construction should be carried out in accordance with BS EN ISO 6946 : 2007, BS EN ISO 13370 : 2007 and *BRE Report BR 443 : 2006*, using the thermal conductivity\* ( $\lambda_D$  value) of 0.022  $W \cdot m^{-1} \cdot K^{-1}$ . The U value of a floor will depend on the thickness of the product, the perimeter/area ratio and the floor type. U values of example floors are shown in Table 2.

Table 2 Floor U values ( $W \cdot m^{-2} \cdot K^{-1}$ )<sup>(1)</sup>

Floor type	Perimeter/area ratio	Insulation thickness (mm)		
		50	75	100
Ground-supported slab <sup>(2)</sup>	0.2	0.18	0.15	0.13
	0.4	0.24	0.19	0.15
	0.6	—	0.21	0.17
	0.8	—	0.22	0.17
	1.0	—	0.23	0.18
Suspended timber floor <sup>(2)(3)(4)</sup>	0.2	0.23	0.20	0.17
	0.4	—	0.24	0.20
	0.6	—	—	0.22
	0.8	—	—	0.22
	1.0	—	—	0.23
Suspended beam-and-block floor <sup>(2)(3)(4)</sup>	0.2	0.19	0.16	0.13
	0.4	0.24	0.19	0.15
	0.6	—	0.20	0.16
	0.8	—	0.21	0.17
	1.0	—	0.21	0.17

(1) Edge insulation not included.

(2) Wall thickness (w) 0.3 m.

(3) Supporting wall ( $U_w$ ) 1.5  $W \cdot m^{-2} \cdot K^{-1}$ .

(4) Ventilation area (e) 0.0015  $m^2 \cdot m^{-1}$ .



6.2 The product can maintain, or contribute to maintaining, continuity of thermal insulation at junctions between elements. For Accredited Construction Details, the corresponding  $\psi$ -values (psi) in *BRE Information Paper IP 1/06*, Table 3 may be used in carbon emission calculations in Scotland and Northern Ireland. Detailed guidance for other junctions and on limiting heat loss by air infiltration can be found in:

**England and Wales** — Approved Documents to Part L and for new thermal elements to existing buildings, Accredited Construction Details (version 1.0). See also SAP 2009 *The Government's Standard Assessment Procedure for Energy Rating of Dwellings*, Appendix K and the *iSBEM User Manual* for new-build

**Scotland** — Accredited Construction Details (Scotland)

**Northern Ireland** — Accredited Construction Details (version 1.0).

6.3 The Certificate holder has at least one member of staff who has been deemed competent by the BBA under the BBA/TIMSA Scheme for Calculation Competency (U value and Condensation Risk Analysis). Competent persons should be contacted for accurate, quality-assured U value and condensation risk analysis. The Certificate of Competency can be found on the BBA website ([www.bbacerts.co.uk](http://www.bbacerts.co.uk)) as Certificate number CS/1006.

## 7 Condensation

### Interstitial condensation



7.1 Floors will adequately limit the risk of interstitial condensation when they are designed and constructed in accordance with BS 5250 : 2011, Annex F, and BS EN ISO 10456 : 2007.

7.2 For suspended timber ground floors, it is not necessary to introduce a VCL as long as adequate sub-floor cross ventilation is provided.

7.3 When the product is used above the dpm on a ground-supported floor, or on a beam-and-block floor, a VCL is installed on the warm side of the insulation to inhibit the risk of interstitial condensation on the upper slab surface.

7.4 For the purposes of assessing the risk of interstitial condensation, the insulation core vapour resistivity may be taken as approximately  $300 \text{ MN}\cdot\text{s}\cdot\text{g}^{-1}\cdot\text{m}^{-1}$  and  $7000 \text{ MN}\cdot\text{s}\cdot\text{g}^{-1}$  for each individual foil-facing.

### Surface condensation



7.5 Floors will adequately limit the risk of surface condensation when the thermal transmittance (U value) does not exceed  $0.7 \text{ W}\cdot\text{m}^{-2}\cdot\text{K}^{-1}$  at any point, and the junctions with walls are designed in accordance with the relevant requirements of *Limiting thermal bridging and air leakage : Robust construction details for dwellings and similar buildings* TSO 2002 or *BRE Information Paper IP 1/06*.



7.6 Floors will adequately limit the risk of surface condensation when the thermal transmittance (U value) does not exceed  $1.2 \text{ W}\cdot\text{m}^{-2}\cdot\text{K}^{-1}$  at any point. Guidance may be obtained from BS 5250 : 2011 Annex F and *BRE Report BR 262 : 2002*.

## 8 Behaviour in relation to fire

The product is combustible, but when properly installed, the product will not add significantly to any existing fire hazard. The product will be contained within the floor by the overlay until the overlay itself is destroyed. Therefore, the product will not contribute to the development stages of a fire.

## 9 Floor loading

9.1 The Certificate holder has declared a designation code CS(10\Y)150 in accordance with BS EN 13165 : 2012 (compressive stress\* at 10% deformation to BS EN 826 : 2013).



9.2 The product is suitable for occupancies defined in this Certificate when covered with a suitable floor covering (see section 4.5) and is capable of resisting a uniformly distributed load of  $1.5 \text{ kNm}^2$  and a concentrated load of 2 kN for category A1 and A2 (domestic) situations as defined in BS EN 1991-1-1 : 2002 and Table NA2 of its National Annex. Further assessment is necessary in the case of duty walkways and floors subject to physical activities.

9.3 The ability of the floor finishes to resist the loads should be confirmed by the flooring overlay specification. The performance of the floor construction will depend on the insulation properties and type of floor covering used (including thickness and strength). Further guidance on the suitability of floor coverings can be found in BS EN 13810-1 : 2002, DD CEN/TS 13810-2 : 2003, BS 8204-1 : 2003 and BS EN 312 : 2010 and from the flooring manufacturer.

## 10 Maintenance

The product is confined within the floor and has suitable durability (see section 11) therefore maintenance is not required.

## 11 Durability



The insulation is rot-proof, dimensionally stable and, when installed with the overlays specified in this Certificate, will remain effective as an insulating material for the life of the building in which it is incorporated.

## 12 General

12.1 Installation of Xtratherm Thin-R Underfloor Board (XT/UF) must be in accordance with the Certificate holder's installation instructions and the requirements of this Certificate.

12.2 Typical methods are shown in Figures 1 to 8, reference should also be made to *BRE Report BR 262 : 2002*.

Figure 1 Ground-supported concrete floor — screed overlay

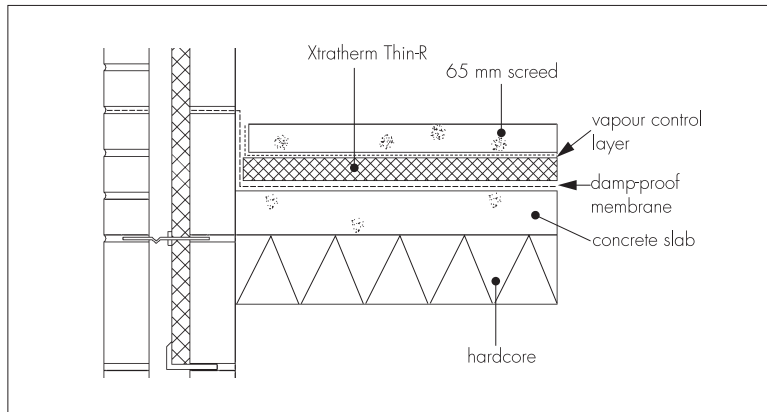

Figure 2 Suspended concrete floor — screed overlay

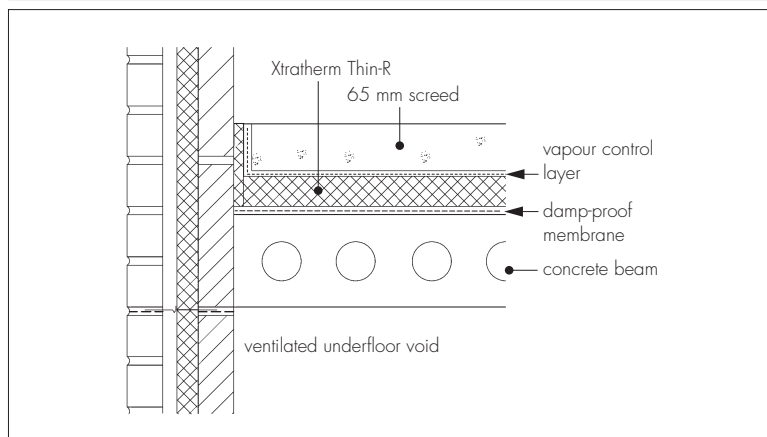

Figure 3 Concrete slab overlay

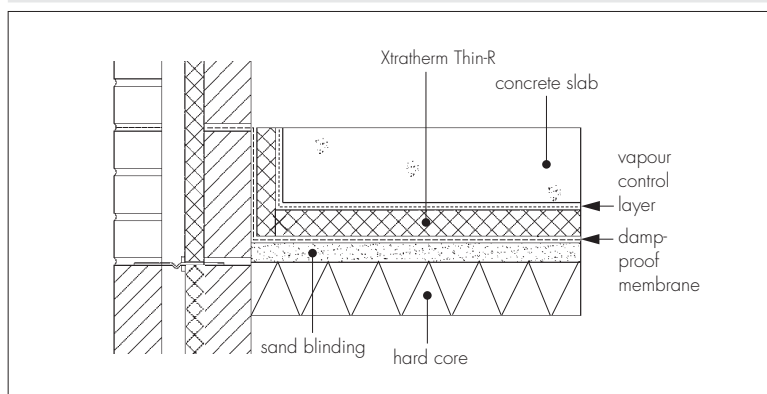

Figure 4 Ground-supported concrete floor — board overlay

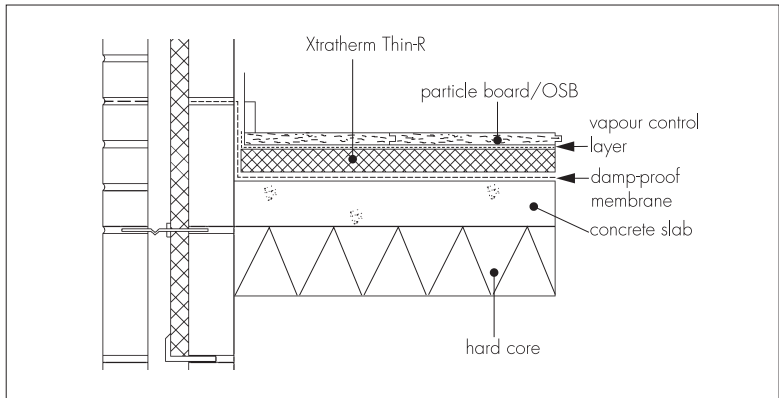

Figure 5 Suspended concrete floor — board overlay

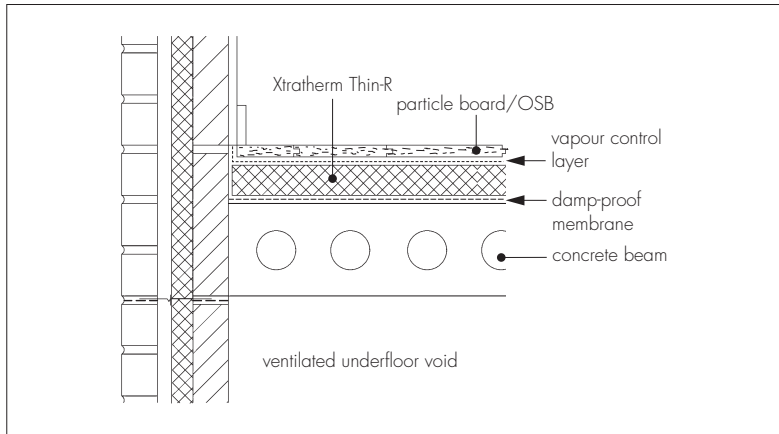

Figure 6 Ground-supported blinded hard core — board overlay

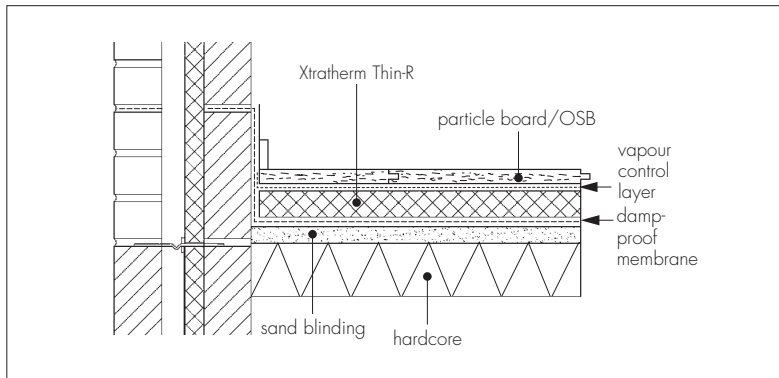

Figure 7 Suspended timber floors

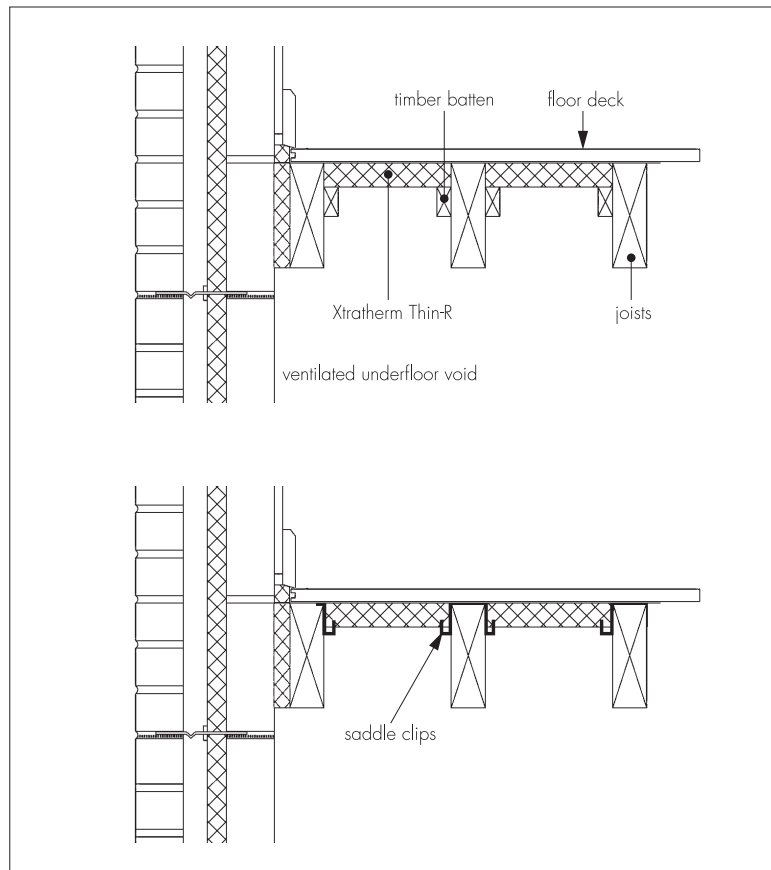
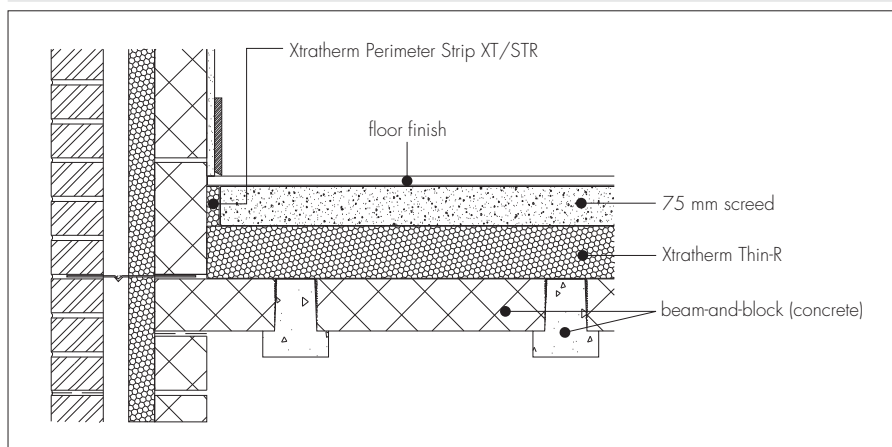

Figure 8 Beam-and-block floor — screed overlay



12.3 All concrete floor surfaces should be smooth, level and flat to within 5 mm when measured with a 2 metre straight-edge. Irregularities greater than this must be removed. Minor irregularities (up to 10 mm deep) may be levelled with mortar or thin screed.

12.4 In ground-supported concrete floors, the concrete floor slab over which the product is laid should be left for as long as possible to maximise drying out and the dissipation of construction moisture, in accordance with BS 8203 : 2001, Section 3.1.2.

12.5 Where the product is used over ground-supported concrete floor slabs, a suitable dpm must be installed in accordance with CP 102 : 1973, Section 11 and BS 8204-1 : 2003 or BS 8204-2 : 2003, to resist moisture from the ground. If a liquid-type dpm is applied to the slabs, it should be of a type compatible with the product and be allowed to dry out fully prior to installing the insulation.

12.6 Ground floors with a hardcore base must be compacted and blinded with a thin layer of sand before laying the dpm, product and concrete slab.

12.7 The product can be used on beam-and-block suspended concrete floors that have been designed and installed to the precast and general loading codes that have been assessed as suitable or that are the subject of a current BBA Certificate. It should be installed in accordance with, and within the limitations imposed by, that Certificate.



12.8 Where a screed or concrete slab is laid over the product, vertical upstands of insulation should be provided and be of sufficient depth to fully separate the screed or slab from the wall. If used, a suitable cavity wall insulation material can be extended below the damp-proof course (dpc) level to provide edge insulation to the floor.

12.9 In suspended timber floors, the product is installed between the floor joists.

12.10 To limit the risk of damage from condensation and other sources of dampness, the product and overlays should only be laid after the construction is made substantially weathertight, eg after glazing. During construction, the product must also be protected from water spillage, plaster droppings and traffic.

12.11 The product can be cut using a sharp knife or fine-toothed saw to fit around service penetrations.

## 13 Procedure

13.1 The product is cut to size and laid with closely-butted, staggered cross-joints, ensuring that all spaces are completely filled.

13.2 The laying pattern should ensure that all cut edges are at the perimeter of the floor or some other feature, eg mat wells, thresholds or access ducts. Spreader boards should be used to protect the product.

### Timber-based board overlay

13.3 Before laying the timber overlay, pre-treated timber battens in accordance with BS 8417 : 2011, are positioned at doorways and at access panels, and to support partitions. Adequate time should be allowed for solvents from solvent-based preservatives to evaporate.

13.4 When the dpc is laid below the slab, a VCL polyethylene sheet of minimum thickness 250  $\mu\text{m}$ , is laid between the product and the overlay boards. The polyethylene sheet must have 150 mm overlaps taped at the joints and turned up 100 mm at the walls.

13.5 Tongue-and-groove 18 mm thick flooring grade, particle board (type P4 to P7), or oriented strand board OSB/2 to OSB/4, is laid with staggered cross-joints in accordance with DD CEN/TS 12872 : 2007 and BS EN 12871 : 2010.

13.6 An expansion gap between the overlay board and the perimeter walls should be provided at the rate of 2 mm per metre run or a minimum of 10 mm, whichever is the greater.

13.7 Where there are long, uninterrupted lengths of floor, eg corridors, proprietary expansion joints should be installed at intervals on the basis of a 2 mm gap per metre run of overlay board.

13.8 Before the overlay boards are interlocked, a waterproof PVA adhesive is applied to the joints.

13.9 Once the overlay board is laid, temporary wedges are inserted between the walls and the floor to maintain tight joints until the adhesive has set.

13.10 When the wedges are removed and before the skirting boards are fixed, a suitable compressible filler, eg foamed polyethylene, should be fitted around the perimeter of the floor between the overlay board and the walls.

13.11 Where there is a likelihood of regular water spillage in rooms such as kitchens, bathrooms, shower and utility rooms, additional particle board protection should be considered, eg by a continuous flexible vinyl sheet flooring, with welded joints, turned up at abutments and cove skirting.

### Cement-based screed overlay

13.12 Perimeter edge pieces are cut and placed around the edges and all floor joints taped, or a polythene VCL, minimum 125  $\mu\text{m}$  thick, is laid over the product with 150 mm laps. A compacted screed is then poured over to a depth of 65 mm for a domestic dwelling. The relevant clauses of BS 8204-1 : 2003 should be followed and *BRE Digest 224 : 1981* and *BRE Digest 104 : 1973* should be consulted.

### Concrete slab overlay (ground-bearing only)

13.13 Perimeter edge pieces are cut and placed around the edges and taped at joints. A polythene VCL, minimum 125  $\mu\text{m}$  thick, is laid over the product with 150 mm laps. The concrete slab is laid to the required thickness in accordance with BS 8000-9 : 2003 and BS 8204-1 : 2003.

### Suspended timber floors

13.14 Saddle clips are placed at intervals (not exceeding one metre) along the timber floor joists. Where the product is to be installed only on one side of a joist, twin clips can be cut into single clips and nailed into place with galvanized nails.

13.15 If saddle clips are not used, the product may be retained using preservative-treated timber battens. Battens should be wide enough to retain the product in place and secured in place with corrosion protected nails at a depth that will accommodate the thickness of the product.

13.16 The product should be cut to fit tightly between joists and pushed down onto the spikes of the saddle clips, or onto the beads. Small gaps should be insulated with cut strips of the product.

## 14 Incorporation of services

14.1 De-rating of electrical cables should be considered where the insulation restricts air cooling of cables. The product must not be used in direct contact with electrical heating cables or hot water pipes.

14.2 Where the product is installed on a floor of a suspended beam and block design, all services must be installed in accordance with the BBA Certificate for that floor and/or with the relevant codes of practice.

14.3 Where possible, electrical conduits, gas and water pipes or other services should be contained within ducts or channels within the concrete slab. Where this is not possible, the services may be accommodated within the product, provided they are securely fixed to the concrete slab. Electrical cables should be enclosed in a suitable conduit. With hot pipes, the product must be cut back to maintain an air space.

14.4 Where water pipes are installed below the product they should be pre-lagged. Pipes installed above the product do not require lagging, although some provision may be needed for expansion and contraction.

14.5 In situations where access to the services is desirable on board overlay floors, a duct may be formed by mechanically fixing to the floor, timber bearers of the same thickness as the product to provide support for a particle board cover. The duct should be as narrow as possible and not exceed 400 mm in width or the maximum particle board spans given in DD CEN/TS 12872 : 2007 without intermediate support. Services should be suitably fixed to the floor base and not to the product (see section 6.2 with regard to limiting heat loss).

## Technical Investigations

### 15 Tests

Tests were carried out on Xtratherm Safe-R Underfloor Insulation by the BBA in accordance with BS EN 13165 : 2012 to determine:

- dimensional stability
- compressive strength
- short-term water absorption
- long-term water absorption by partial immersion
- thermal conductivity
- compressive creep
- bowing under a thermal gradient.

### 16 Investigations

16.1 The manufacturing process was examined, including the methods adopted for quality control, and details were obtained of the quality and composition of the materials used.

16.2 An assessment was made of the results of test data to BS EN 13165 : 2012 in relation to:

- dimensions
- squareness
- density
- $\lambda$  value.

16.3 An assessment of the risk of interstitial condensation was made.

16.4 An assessment was made of typical constructions which achieve the design U values.

## Bibliography

- BS 5250 : 2011 *Code of practice for control of condensation in buildings*
- BS 8000-9 : 2003 *Workmanship on building sites — Cementitious levelling screeds and wearing screeds — Code of practice*
- BS 8102 : 2009 *Code of practice for protection of structures against water from the ground*
- BS 8203 : 2001 *Code of practice for installation of resilient floor coverings*
- BS 8204-1 : 2003 *Screeds, bases and in-situ floorings — Concrete bases and cementitious levelling screeds to receive floorings — Code of practice*
- BS 8204-2 : 2003 *Screeds, bases and in-situ floorings — Concrete wearing surfaces — Code of practice*
- BS 8215 : 1991 *Code of practice for design and installation of damp-proof courses in masonry construction*
- BS 8417 : 2011 *Preservation of wood — Code of practice*
- BS EN 300 : 2006 *Oriented Strand Boards (OSB) — Definitions, classification and specifications*
- BS EN 312 : 2010 *Particleboards — Specifications*
- BS EN 826 : 2013 *Thermal insulating products for building applications — Determination of compression behaviour*
- BS EN 1991-1-1 : 2002 *Eurocode 1 : Actions on structures — General actions — Densities, self-weight, imposed loads for buildings*
- NA to BS EN 1991-1-1 : 2002 *UK National Annex to Eurocode 1 : Actions on structures — General actions — Densities, self-weight, imposed loads for buildings*
- BS EN 12871 : 2010 *Wood-based panels — Performance specifications and requirements for load bearing boards for use in floors, walls and roofs*
- BS EN 13165 : 2012 *Thermal insulation products for buildings — Factory made rigid polyurethane foam (PU) products — Specification*
- BS EN 13810-1 : 2002 *Wood-based panels — Floating floors — Performance specifications and requirements*
- BS EN ISO 6946 : 2007 *Building components and building elements — Thermal resistance and thermal transmittance — Calculation method*
- BS EN ISO 9001 : 2008 *Quality management systems — Requirements*
- BS EN ISO 10456 : 2007 *Building materials and products — Hygrothermal properties — Tabulated design values and procedures for determining declared and design thermal values*
- BS EN ISO 13370 : 2007 *Thermal performance of buildings — Heat transfer via the ground — Calculation methods*
- CP 102 : 1973 *Code of practice for protection of buildings against water from the ground*
- DD CEN/TS 12872 : 2007 *Wood-based panels — Guidance on the use of load-bearing boards in floors, walls and roofs*
- DD CEN/TS 13810-2 : 2003 *Wood-based panels — Floating floors — Test methods*
- BRE Information Paper IP 1/06 *Assessing the effects of thermal bridging at junctions and around openings*
- BRE Digest 104 : 1973 *Floor screeds*
- BRE Digest 224 : 1981 *Cellular Plastics for Buildings. Floors*
- BRE Report (BR 262 : 2002) *Thermal insulation: avoiding risks*
- BRE Report (BR 443 : 2006) *Conventions for U-value calculations*

## 17 Conditions

17.1 This Certificate:

- relates only to the product/system that is named and described on the front page
- is issued only to the company, firm, organisation or person named on the front page — no other company, firm, organisation or person may hold or claim that this Certificate has been issued to them
- is valid only within the UK
- has to be read, considered and used as a whole document — it may be misleading and will be incomplete to be selective
- is copyright of the BBA
- is subject to English Law.

17.2 Publications, documents, specifications, legislation, regulations, standards and the like referenced in this Certificate are those that were current and/or deemed relevant by the BBA at the date of issue or reissue of this Certificate.

17.3 This Certificate will remain valid for an unlimited period provided that the product/system and its manufacture and/or fabrication, including all related and relevant parts and processes thereof:

- are maintained at or above the levels which have been assessed and found to be satisfactory by the BBA
- continue to be checked as and when deemed appropriate by the BBA under arrangements that it will determine
- are reviewed by the BBA as and when it considers appropriate.

17.4 The BBA has used due skill, care and diligence in preparing this Certificate, but no warranty is provided.

17.5 In issuing this Certificate, the BBA is not responsible and is excluded from any liability to any company, firm, organisation or person, for any matters arising directly or indirectly from:

- the presence or absence of any patent, intellectual property or similar rights subsisting in the product/system or any other product/system
- the right of the Certificate holder to manufacture, supply, install, maintain or market the product/system
- actual installations of the product/system, including their nature, design, methods, performance, workmanship and maintenance
- any works and constructions in which the product/system is installed, including their nature, design, methods, performance, workmanship and maintenance
- any loss or damage, including personal injury, howsoever caused by the product/system, including its manufacture, supply, installation, use, maintenance and removal
- any claims by the manufacturer relating to CE marking.

17.6 Any information relating to the manufacture, supply, installation, use, maintenance and removal of this product/system which is contained or referred to in this Certificate is the minimum required to be met when the product/system is manufactured, supplied, installed, used, maintained and removed. It does not purport in any way to restate the requirements of the Health and Safety at Work etc. Act 1974, or of any other statutory, common law or other duty which may exist at the date of issue or reissue of this Certificate; nor is conformity with such information to be taken as satisfying the requirements of the 1974 Act or of any statutory, common law or other duty of care.