



INNOVATIVE | RELIABLE | EFFICIENT

# DISCOVER A NEW LEVEL OF EFFICIENCY

HOME HEATING PRODUCT RANGE  
OIL / RENEWABLES / CYLINDERS

## HEAD OFFICE

Warmflow House  
Lissie Industrial Estate  
Moira Road  
Lisburn  
BT28 2RF  
Northern Ireland

T: +44 (0) 2892 621 515  
sales@warmflow.co.uk

## GREAT BRITAIN

Warmflow House, Unit C4  
Stafford Park 4,  
Telford,  
TF3 3BA  
England

T: +44 (0) 1952 607 750  
salesgb@warmflow.co.uk

## INTERNATIONAL

Avda. de Los Castros, 33  
Portal 2 – 1B  
Santander  
39005  
Cantabria  
Spain

T: +34 (0) 942 140 623  
info@warmflow.es



Warmflow Engineering Company Limited is a family owned company where reputation and integrity are paramount. We maintain a policy of continuous product improvement and reserve the right to change specification without notice. The statutory rights of the consumer are not affected. This brochure should only be used for sales purposes. Please consult the installation instructions, available on request, before installing or specifying a Warmflow product.

6665 ISSUE 1



www.warmflow.co.uk



INNOVATIVE | RELIABLE | EFFICIENT



KEEPING FAMILIES WARM

# 50 YEARS OF HEATING

Warmflow has created innovative, award-winning home heating products for over 50 years.

All Warmflow products are made at our state of the art manufacturing facility in Lisburn. Our extensive range of home heating products offer value for money, fuel efficiency, ease of installation and top class customer care.

Our comprehensive product portfolio includes the only AA rated boiler, a choice of highly efficient, intelligent renewable products and a selection of cylinders which will satisfy the needs of the most demanding households.

At Warmflow we pride ourselves on leading the way in innovation, working with customers to ensure that:

- we manufacture products which are easy to install and service
- our products are made using only the highest quality materials
- they deliver the highest available efficiency levels and cost savings.



Our products have been independently tested and accredited. Our range of appliances exceed the minimum ErP efficiency requirements and comply with Document L1A, L1B (England & Wales), The Building Standards (Scotland) Regulations Section 6, Approved Document Part F (Northern Ireland) and with the HARP efficiency requirements for Part L (Republic of Ireland).



# Agentis

## OIL BOILERS

Our outstanding selection of high efficiency, internal and external oil-fired boilers including the only AA-rated oil boiler will keep your customers and their loved ones warm and cosy during the chilly months ahead.

WARMFLOW  
**Agentis**  
High Efficiency Oil Boiler



★ Trustpilot



I have been fitting warmflow boilers for several years and can not fault them one bit. Competitive price and a high quality build. The warmflow team could not be more helpful unlike competitors. Nice as an installer to have regular contact and professional development with a team determined to make the installation of an oil fired boiler as easy and painless for both installer and consumer. Highly recommended.





**WARMFLOW**  
**Agentis**  
High Efficiency Oil Boiler



**INTERNAL HEAT ONLY**

I21 / I26 / I33 / I44

- High-efficiency condensing Internal range
- Designed to fit into any kitchen or utility room
- The latest Riello low NOx technology



AVAILABLE AS  
**WARMFLOW**  
**PROFESSIONAL**



**INTERNAL PUMPED**

I21 P / I26 P / I33 P / I44 P

- Riello low NOx technology
- Factory-fitted Grundfos UPM3 FLEX AS circulating pump
- Factory-fitted automatic air vent
- Factory-fitted 3-bar safety valve

**INTERNAL OIL BOILERS**

Designed to fit specifically into kitchen and utility rooms, its stylish white casing houses a highly efficient patented heat exchanger and the latest Riello low NOx technology.



The only AA-rated oil boiler, which offers an average saving of 5 litres of fuel per week compared to other brands\*



Unique “Easy-Fit” balanced flue system - 1 flue fits all boilers



Patented high-efficiency heat exchanger



New slimline design integrates seamlessly into any kitchen or utility room



Latest Riello low NOx technology exceeding legislative requirements



Range of outputs from 15 – 44kW

**WARMFLOW**  
**PROFESSIONAL**

All Warmflow Professional models come with:



**£250**

WORTH OF  
FACTORY-FITTED EXTRAS

See page 10 for more details.

★ Trustpilot



AVAILABLE AS  
**WARMFLOW**  
**PROFESSIONAL**



**INTERNAL SYSTEM**

I21 S / I26 S / I33 S

- Riello low NOx technology
- Factory-fitted Grundfos UPM3 FLEX AS circulating pump
- 12l Expansion vessel
- Factory-fitted automatic air vent
- Factory-fitted 3-bar safety valve



AVAILABLE AS  
**WARMFLOW**  
**PROFESSIONAL**



**INTERNAL COMBI**

I21 C / I26 C / I33 C

- AA Rating on M & XL load profile
- Riello low NOx technology
- Factory fitted Grundfos UPM3 FLEX AS circulating pump
- 24l Factory-fitted, hinged, expansion vessel
- Low component count
- DHW Expansion vessel
- DCW Inlet shut-off valve
- Factory-fitted DCW pressure reducing valve
- Push-in O-ring fittings
- Slimline design
- Integrated 7-day programmer
- Patented design

\*Figures based on manufacturer's official ErP Data Published June 18



**WARMFLOW Agentis**  
High Efficiency Oil Boiler



**EXTERNAL HEAT ONLY**

E21 / E26 / E33 / E44

- Latest Riello low NOx technology



AVAILABLE AS  
**WARMFLOW PROFESSIONAL**



**EXTERNAL PUMPED**

E21 P / E26 P / E33 P / E44 P

- Riello low NOx technology
- Factory-fitted Grundfos UPM3 FLEX AS circulating pump
- Factory-fitted automatic air vent
- Factory-fitted 3-bar safety valve

**EXTERNAL OIL BOILERS**

Designed for outdoor use with its IP45-rated, no maintenance, weatherproof casing, the Warmflow Agentis also features a highly efficient, patented heat exchanger and the latest Riello low NOx technology.

**WARMFLOW PROFESSIONAL**

All Warmflow Professional models come with:



**£250**

WORTH OF FACTORY-FITTED EXTRAS

See page 10 for more details.



Save up to 5 litres of fuel per week compared to other brands with the only AA-rated oil boiler\*



Patented high-efficiency heat exchanger



Multi-directional flue options included as standard



Latest Riello low NOx technology exceeding legislative requirements



Range of outputs from 15 – 44kW



AVAILABLE AS  
**WARMFLOW PROFESSIONAL**



**EXTERNAL SYSTEM**

E21 S / E26 S / E33 S

- Riello low NOx technology
- Factory-fitted Grundfos UPM3 FLEX AS circulating pump
- 12l Expansion vessel
- Factory-fitted automatic air vent
- Factory-fitted 3-bar safety valve



AVAILABLE AS  
**WARMFLOW PROFESSIONAL**



**EXTERNAL COMBI**

E21 C / E26 C / E33 C

- AA Rating on M & XL load profile
- Riello low NOx technology
- Factory fitted Grundfos UPM3 FLEX AS circulating pump
- 24l Factory-fitted, hinged, expansion vessel
- Low component count
- DHW expansion vessel
- DCW inlet shut-off valve
- Factory-fitted DCW pressure reducing valve
- Push-in O-ring fittings
- Slimline design
- Integrated 7-day programmer
- Patented design

★ Trustpilot



\*Figures based on manufacturer's official ErP Data Published June 18



**WARMFLOW**  
**Agentis**  
High Efficiency Oil Boiler



## BOILERHOUSE OIL BOILERS

The Boilerhouse range has been specifically designed for boiler house and garage applications and is suitable for indoor installation.

Its blue casing houses a highly efficient heat exchanger that can be easily accessed for servicing. The latest in Riello low NOx burner technology makes the Boilerhouse range quiet in operation and the perfect choice in oil-fired boilers.

All Boilerhouse models are fully factory wired with burner and thermostat and are supplied with a factory-fitted condensate trap as standard. The appliance has flow and return connections off the top for ease of plumbing.



Range of outputs from 15 – 33kW



### GOOD TO KNOW

The Boilerhouse Boilers are supplied with a pre-wired, factory-fitted burner and thermostat. Only one IE320 mains socket (supplied) needs to be wired on site.



### AN ENVIRONMENTAL INVESTMENT

Designed to be environmentally friendly, Warmflow boilers are highly efficient in operation and are ErP A-rated.

★ Trustpilot



All boilers are compatible with biofuel however they must be commissioned on site and the flexible fuel line(s), nozzle and fuel filter replaced. Please contact Warmflow for further details.

# THE NEXT GENERATION OF OIL BOILERS

**WARMFLOW**  
**Agentis**  
High Efficiency Oil Boiler  
**PROFESSIONAL**



**7**  
YEAR HEAT EXCHANGER WARRANTY\*

★ Trustpilot



Teddington fire valve with 9m capillary<sup>†</sup>



Oil line installation kit with a Crossland oil filter



ADEY Magnaclean pro 2 filter



Pre-wired Grundfos UPM3 Flex AS Circulating Pump



Includes 2 Bottles of Inhibitor

<sup>†</sup>9m capillary as standard with an Internal boiler, 3m capillary as standard with an External boiler.

\*Subject to terms and conditions. Visit [www.warmflow.co.uk](http://www.warmflow.co.uk) for more details.

# MODEL SPECIFICATIONS

INTERNAL													
Model	Output (kW)	Flue Options	C/F size (mm)	ErP Rating			Height (mm)	Depth (mm)	Width (mm)	Connections		Service Access	DHW Flow (l/min)
				CH	DHW	Flow				Return			
				M	XL								
<b>HEAT ONLY</b>													
I21	15-21	C/F, low/ high/ vertical B/F	100	A	n/a	n/a	865	602	413	28mm	1" BSP	front	n/a
I26	21-27	C/F, low/ high/ vertical B/F	100	A	n/a	n/a	865	602	413	28mm	1" BSP	front	n/a
I33	27-33	C/F, low/ high/ vertical B/F	100	A	n/a	n/a	865	602	413	28mm	1" BSP	front	n/a
I44	33-44	C/F, low/ high/ vertical B/F	100	A	n/a	n/a	1155	872	595	1 1/4" BSP	1 1/4" BSP	front	n/a
<b>PRE PUMPED</b>													
I21P	15-21	C/F, low/ high/ vertical B/F	100	A	n/a	n/a	865	602	413	28mm	22mm	front	n/a
I26P	21-27	C/F, low/ high/ vertical B/F	100	A	n/a	n/a	865	602	413	28mm	22mm	front	n/a
I33P	27-33	C/F, low/ high/ vertical B/F	100	A	n/a	n/a	865	602	413	28mm	28mm	front	n/a
I44P	33-44	C/F, low/ high/ vertical B/F	100	A	n/a	n/a	1155	872	595	28mm	1 1/4" BSP	front	n/a
<b>SYSTEM</b>													
I21S	15-21	C/F, low/ high/ vertical B/F	100	A	n/a	n/a	865	602	413	28mm	22mm	front	n/a
I26S	21-27	C/F, low/ high/ vertical B/F	100	A	n/a	n/a	865	602	413	28mm	22mm	front	n/a
I33S	27-33	C/F, low/ high/ vertical B/F	100	A	n/a	n/a	865	602	413	28mm	28mm	front	n/a
<b>COMBI</b>													
I21C	15-21	C/F, low/ high/ vertical B/F	100	A	A	A	865	602	515	22mm	22mm	front/top	18
I26C	21-27	C/F, low/ high/ vertical B/F	100	A	A	A	865	602	515	22mm	22mm	front/top	22*
I33C	27-33	C/F, low/ high/ vertical B/F	100	A	A	A	865	602	515	22/28mm	22/28mm	front/top	24*
<b>PROFESSIONAL</b>													
I21PPRO	15-21	C/F, low/ high/ vertical B/F	100	A	n/a	n/a	865	602	413	28mm	22mm	front	n/a
I26PPRO	21-27	C/F, low/ high/ vertical B/F	100	A	n/a	n/a	865	602	413	28mm	22mm	front	n/a
I33PPRO	27-33	C/F, low/ high/ vertical B/F	100	A	n/a	n/a	865	602	413	28mm	28mm	front	n/a
I21SPRO	15-21	C/F, low/ high/ vertical B/F	100	A	n/a	n/a	865	602	413	28mm	22mm	front	n/a
I26SPRO	21-27	C/F, low/ high/ vertical B/F	100	A	n/a	n/a	865	602	413	28mm	22mm	front	n/a
I33SPRO	27-33	C/F, low/ high/ vertical B/F	100	A	n/a	n/a	865	602	413	28mm	28mm	front	n/a
I21CPRO	15-21	C/F, low/ high/ vertical B/F	100	A	A	A	865	602	515	22mm	22mm	front/top	18
I26CPRO	21-27	C/F, low/ high/ vertical B/F	100	A	A	A	865	602	515	22mm	22mm	front/top	22*
I33CPRO	27-33	C/F, low/ high/ vertical B/F	100	A	A	A	865	602	515	22/28mm	22/28mm	front/top	24*

\*Remove flow restrictor for above 18l/min. Output dependent on incoming pressure/volume.

EXTERNAL													
Model	Output (kW)	Flue Options	C/F size (mm)	ErP Rating			Height (mm)	Depth (mm)	Width (mm)	Connections		Service Access	DHW Flow (l/min)
				CH	DHW	Flow				Return			
				M	XL								
<b>HEAT ONLY</b>													
E21	15-21	L,R or rear. Optional Top	n/a	A	n/a	n/a	900	700	413	28mm	1" BSP	front	n/a
E26	21-27	L,R or rear. Optional Top	n/a	A	n/a	n/a	900	700	413	28mm	1" BSP	front	n/a
E33	27-33	L,R or rear. Optional Top	n/a	A	n/a	n/a	900	700	413	28mm	1" BSP	front	n/a
E44	33-44	L,R or rear. Optional Top	n/a	A	n/a	n/a	1155	876	595	1 1/4" BSP	1 1/4" BSP	front	n/a
<b>PRE PUMPED</b>													
E21P	15-21	L,R or rear. Optional Top	n/a	A	n/a	n/a	900	700	413	28mm	22mm	front	n/a
E26P	21-27	L,R or rear. Optional Top	n/a	A	n/a	n/a	900	700	413	28mm	22mm	front	n/a
E33P	27-33	L,R or rear. Optional Top	n/a	A	n/a	n/a	900	700	413	28mm	28mm	front	n/a
E44P	33-44	L,R or rear. Optional Top	n/a	A	n/a	n/a	1155	876	595	28mm	1 1/4" BSP	front	n/a
<b>SYSTEM</b>													
E21S	15-21	L,R or rear. Optional Top	n/a	A	n/a	n/a	900	700	413	28mm	22mm	front	n/a
E26S	21-27	L,R or rear. Optional Top	n/a	A	n/a	n/a	900	700	413	28mm	22mm	front	n/a
E33S	27-33	L,R or rear. Optional Top	n/a	A	n/a	n/a	900	700	413	28mm	28mm	front	n/a
<b>COMBI</b>													
E21C	15-21	L,R or rear. Optional Top	n/a	A	A	A	900	700	550	22mm	22mm	front/top	18
E26C	21-27	L,R or rear. Optional Top	n/a	A	A	A	900	700	550	22mm	22mm	front/top	22*
E33C	27-33	L,R or rear. Optional Top	n/a	A	A	A	900	700	550	22/28mm	22/28mm	front/top	24*
<b>PROFESSIONAL</b>													
E21PPRO	15-21	L,R or rear. Optional Top	n/a	A	n/a	n/a	900	700	413	28mm	22mm	front	n/a
E26PPRO	21-27	L,R or rear. Optional Top	n/a	A	n/a	n/a	900	700	413	28mm	22mm	front	n/a
E33PPRO	27-33	L,R or rear. Optional Top	n/a	A	n/a	n/a	900	700	413	28mm	28mm	front	n/a
E21SPRO	15-21	L,R or rear. Optional Top	n/a	A	n/a	n/a	900	700	413	28mm	22mm	front	n/a
E26SPRO	21-27	L,R or rear. Optional Top	n/a	A	n/a	n/a	900	700	413	28mm	22mm	front	n/a
E33SPRO	27-33	L,R or rear. Optional Top	n/a	A	n/a	n/a	900	700	413	28mm	28mm	front	n/a
E21CPRO	15-21	L,R or rear. Optional Top	n/a	A	A	A	900	700	550	22mm	22mm	front/top	18
E26CPRO	21-27	L,R or rear. Optional Top	n/a	A	A	A	900	700	550	22mm	22mm	front/top	22*
E33CPRO	27-33	L,R or rear. Optional Top	n/a	A	A	A	900	700	550	22/28mm	22/28mm	front/top	24*
<b>BOILER HOUSE</b>													
B21	15-21	C/F, low/ high/ vertical B/F	100	A	n/a	n/a	697	600	395	1" BSP	1" BSP	front	n/a
B26	21-27	C/F, low/ high/ vertical B/F	100	A	n/a	n/a	697	600	395	1" BSP	1" BSP	front	n/a
B33	27-33	C/F, low/ high/ vertical B/F	100	A	n/a	n/a	697	600	395	1" BSP	1" BSP	front	n/a

\*Remove flow restrictor for above 18l/min. Output dependent on incoming pressure/volume.

# FLUE & PLUME MANAGEMENT KITS

Warmflow's Easy-Fit, plastic flue systems have been specifically designed for use on high efficiency, condensing oil boilers.

With the Warmflow Agentis range, you don't need to carry different flue systems for different jobs - with us, one flue will fit all our boilers. Additional benefits include the locking clamp arrangement which offers superior rigidity and security compared with traditional push-fit flues. Since the flue system is plastic all extension and terminal sections can be easily cut to length as required.

All flue kits include:

- Boiler adapter and starter piece
- End terminal
- Flue fittings kit
- Thermal guard (FBF)
- 1000mm extension (HBF)
- 87° bend (HBF)

In instances where discharging flue gasses at low level may cause a problem, such as in a small courtyard or narrow passageway, a Plume Management Kit may provide a useful addition to a standard low-level flue. The kit features extensions and bends in 80mm black UV-stabilised polypropylene and also includes adjustable mounting brackets. Plume Management Kits are suitable for all models up to 44kW (see notes).

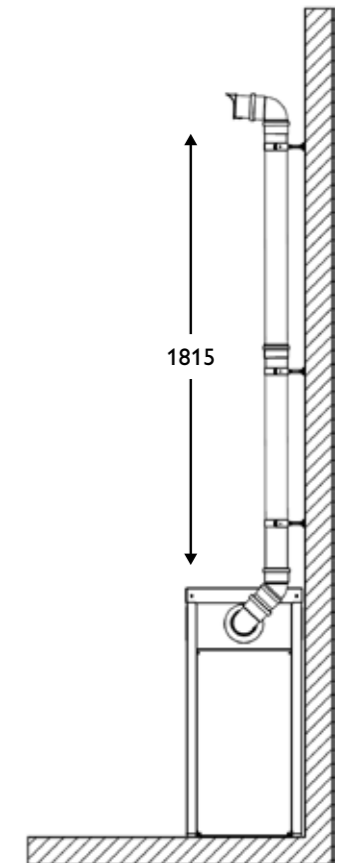
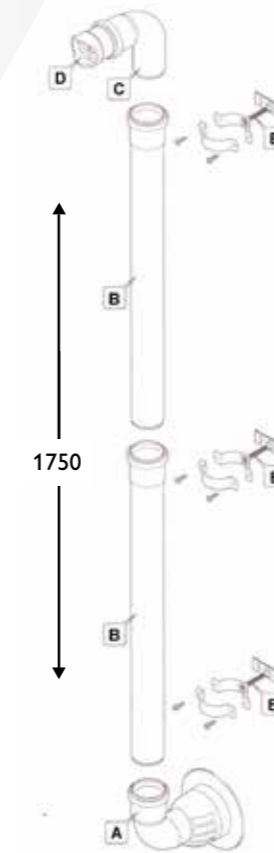

### KEY

- A - Diverter elbow
- B - 860mm extension
- C - 87° bend
- D - Terminal insert
- E - Adjustable bracket
- F - 45° bend

Note: FBF kit also required Utility (Internal) Plume Management Kit (U-Pmk)

Kabin-Pak (External) Plume Management Kit (K-Pmk)

The following components are available separately

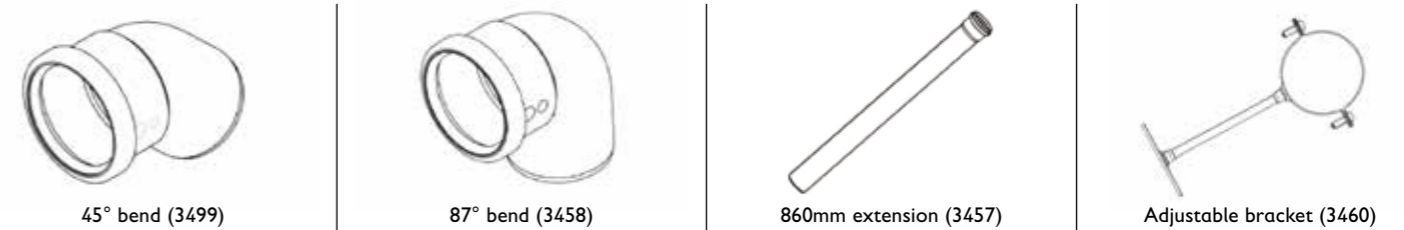

Note: The Utility (Internal) Plume Management Kit (U-PMK) is designed to extend an FBF flue kit. Both an FBF and U-PMK are required to assemble the complete flue.

### HE FLUE KIT ACCESSORIES

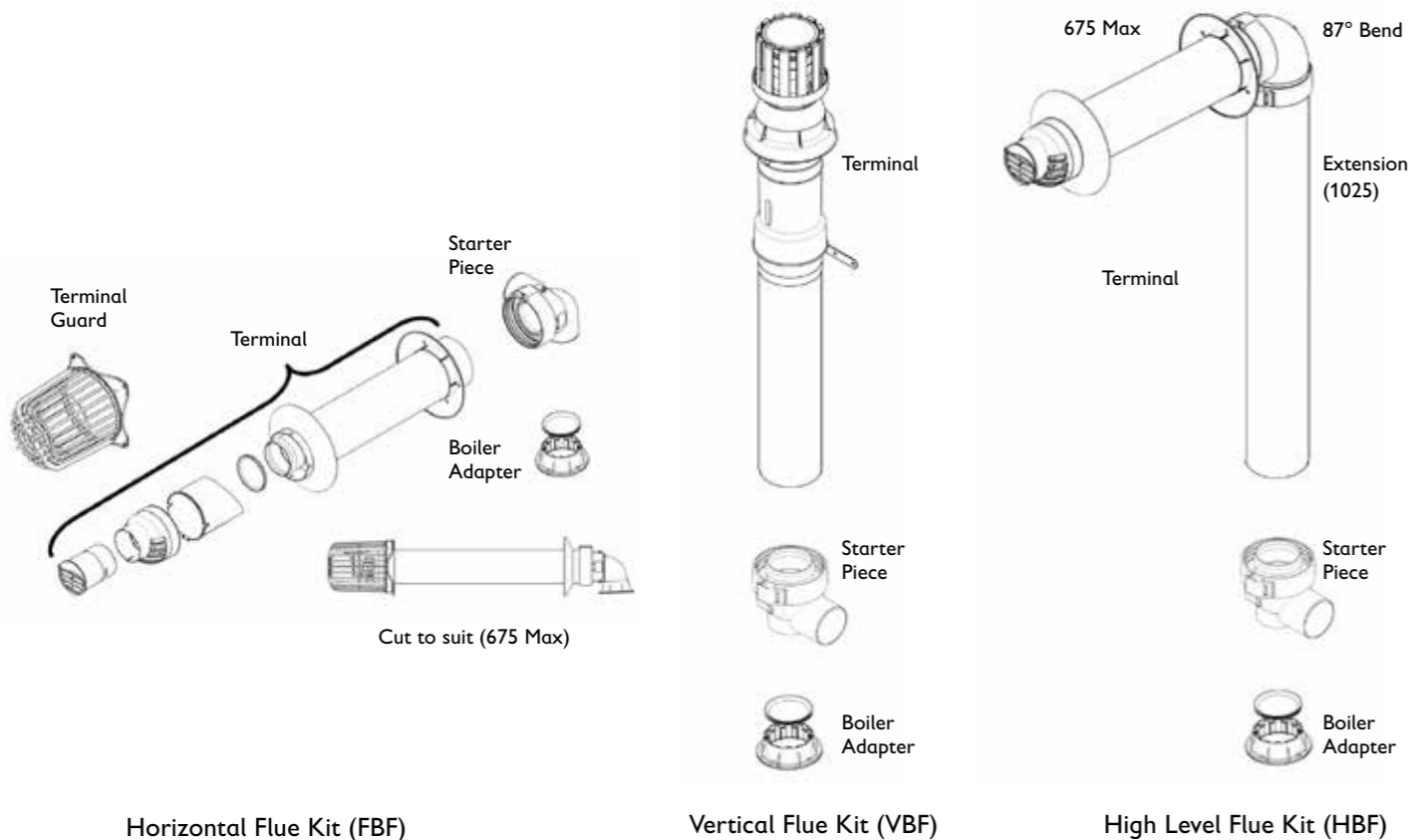
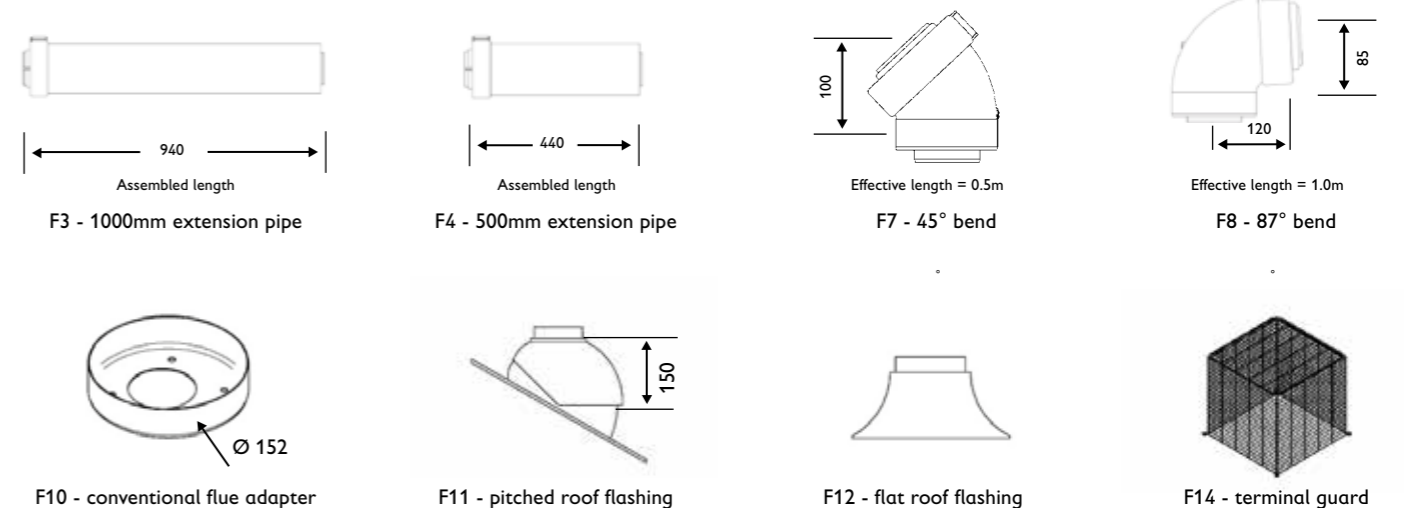

Horizontal Flue Kit (FBF)

Vertical Flue Kit (VBF)

High Level Flue Kit (HBF)



# FLEXI LINER KITS & ACCESSORIES

With Warmflow's flexible flue liners, connecting a condensing boiler to an existing chimney couldn't be easier. No separate combustion air supply is needed as our flue liners use the chimney for the supply of combustion air, providing a room-sealed installation.

With the Agentis range, you don't need to carry different flue systems for different jobs - with us, one flue will fit all our boilers.

Four kits are available in a choice of either 6 metre or 10 metre flexible sections, with either vertical or horizontal entry options. The connection between the boiler and chimney is made using Warmflow's plastic flue system, so both the flexible liner within the chimney and the rigid flue connecting the boiler can easily be cut to length as required.

Flexi Liner Kits are suitable for all indoor models up to 26kW. For outputs in excess of 26kW, please consult our Customer Care Centre.

### All 4 kits include:

- boiler adapter
- vertical starter piece
- flue fittings kit
- flue thermostat
- chimney closure plate
- terminal section
- flexible liner
- liner spacers and couplings

### Horizontal kits also include:

- 2 x 0.5 metre balanced flue extensions
- 1 x 87° balanced flue bend
- 1 x 87° liner support elbow

### Vertical kits also include:

- 1 x 0.5 metre balanced flue extension

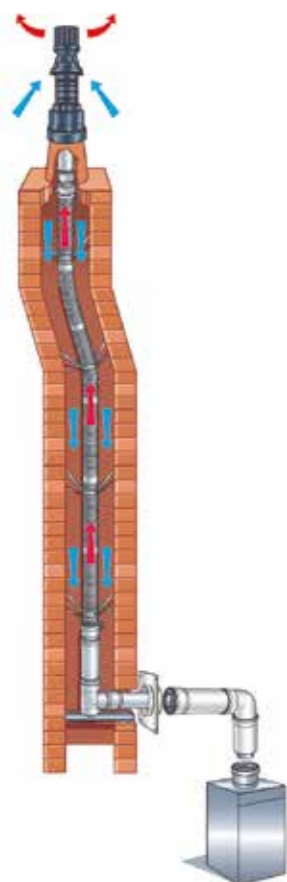

**Vertical Entry Kit**  
 VFL6 = 6m vertical entry kit  
 VFL10 = 10m vertical entry kit

**Horizontal Entry Kit**  
 HFL6 = 6m horizontal entry kit  
 HFL10 = 10m horizontal entry kit

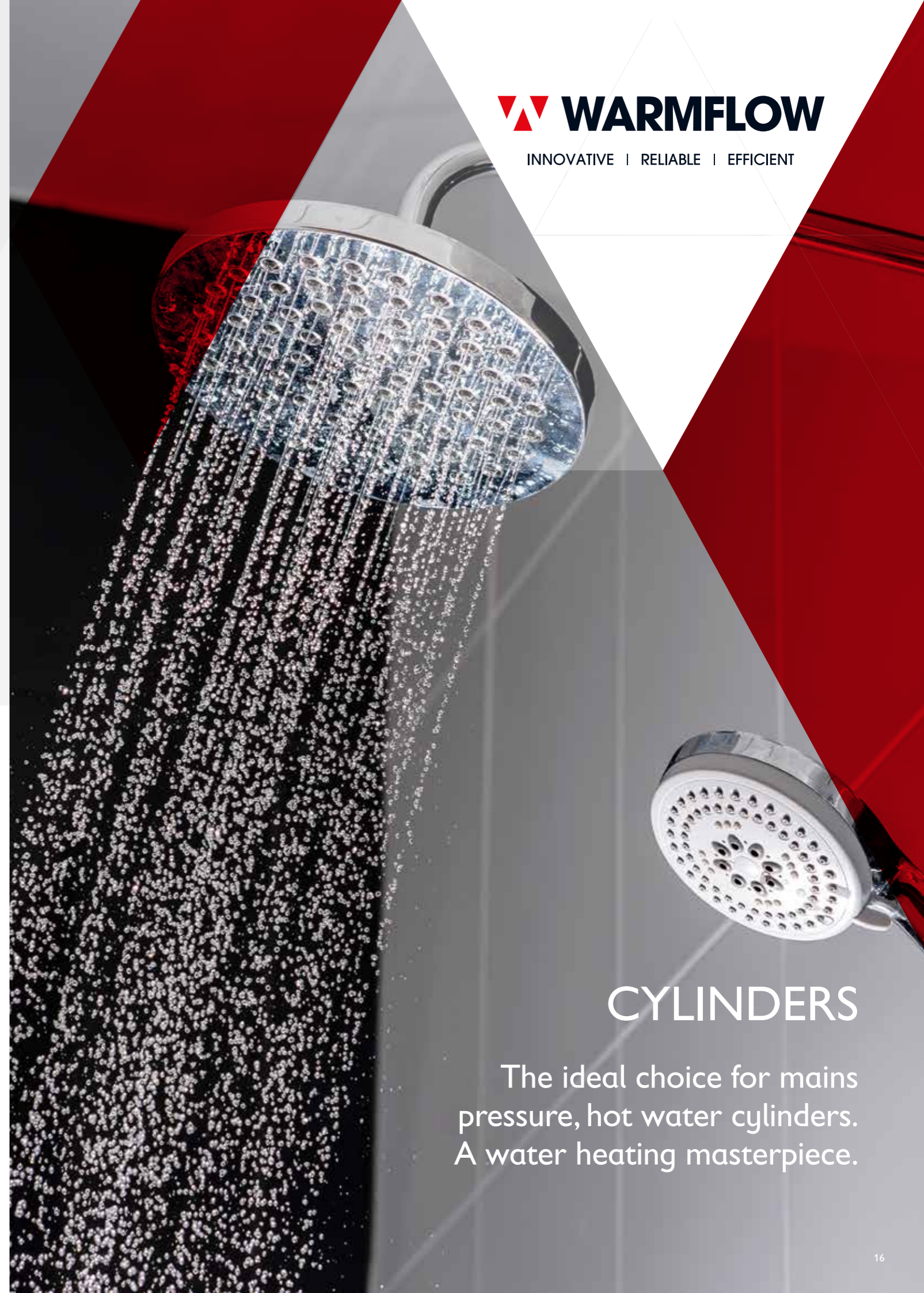
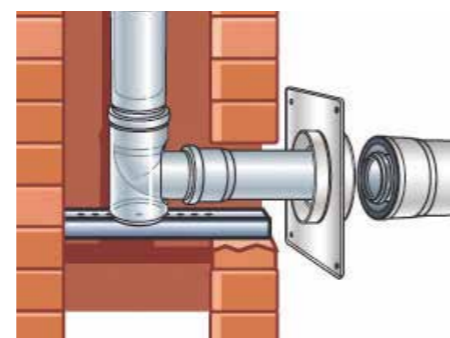

# CYLINDERS

The ideal choice for mains pressure, hot water cylinders. A water heating masterpiece.



## QUALITY DESIGN WITH BUILT-IN RELIABILITY

The cylinder range from Warmflow has been designed to satisfy the hot water needs of even the most demanding consumer.

The innovative design of our range of KIWA-approved, unvented cylinders ensures that you benefit from the largest hot water volumes, shortest heat-up times and lowest possible heat losses. From the large coil-in-coil heat exchangers to the high performance foam insulation, no effort has been spared in developing a market leading hot water cylinder. This is reflected in our premier hot water cylinder which has received top ratings from ERPs.

Our cylinders work at mains pressure, so they provide outstanding hot water flow rates, far exceeding those experienced with a combi boiler or traditional vented cylinder.

As a result, baths fill quickly and showers are invigorating. In addition, due to the inlet control group we supply with a balanced cold water connection, all the hot and cold taps in the house operate at the same pressure and blending valves work at their best to ensure consistent, comfortable hot water temperatures.

Rather than using thin wall corrugated flexible tube for our heat exchanger coils, we use rigid coil-in-coil exchangers formed from high quality stainless steel pipe, as we believe this provides greater stability, quality and durability. Our coils are formed from long lengths of pipe, so they have large surface areas for heat transfer.

All our models are manufactured from high quality Duplex stainless steel, a strong and lightweight material ideal for pressurised cylinders. Our range is fully third-party tested, approved and certified. Employing patented design features, innovative manufacturing techniques and industry best practice, our cylinders have a 'crevice-free' construction which, combined with the use of Duplex stainless steel, ensures corrosion resistance and a long service life.

This, and the fact that we test every cylinder to in excess of the maximum pressure it will experience in operation, means we can confidently offer a 25 year guarantee. So peace of mind comes as standard.

### AN ENVIRONMENTAL INVESTMENT

We use a thick layer of high quality polyurethane insulation our cylinder range has amongst the lowest fully certified heat loss levels currently on the market, saving precious fuel and reducing carbon dioxide emissions.



Our insulation is also CFC/HCFC-free, has a zero Ozone Depletion Potential (ODP) and a Global Warming Potential of only 2. Due to the large surface areas of our coil-in-coil heat exchangers it is also possible for a condensing boiler to work in condensing mode for longer, and cycle less frequently when heating the hot water, thereby helping to further reduce fuel use and emissions.



TRIPLE COIL TR300UV



TWIN COIL TW250UV



ECO DIRECT ED210UV



INDIRECT IN180UV



DIRECT DI 90UV



## INDIRECT CYLINDER

Available in six sizes from 120 to 300 litres to suit the vast majority of domestic installations, our Indirect models are the core of our cylinder range.

Thanks to their large surface area and high performance heat exchange coils, the Indirect models boast impressive heat-up times - the 180 litre model taking just 25 minutes to reach 60°C from cold.

Our Indirect models, like the rest of the range, are designed to be fed directly from the mains water supply via the inlet group supplied, which is capable of receiving incoming water at pressures up to a maximum of 12 bar.

In order to achieve the best performance from our unvented cylinders, the mains water supply must be capable of supplying a flow rate of at least 20 litres per minute with a dynamic pressure of at least 1.5 bar. Should the supply performance be less than this the hot water flow rates will be reduced, however a Warmflow unvented cylinder may still be installed and the benefits of a fast heat-up time and minimal heat losses can still be enjoyed.



## EASE OF INSTALLATION

Our cylinders are supplied with all the necessary parts for a quick, easy, professional installation. We supply only high quality components from recognised, market-leading suppliers and factory fit the temperature and pressure relief valve (T&P) and all cylinder thermostats for convenience and safety.

### COMPONENTS SUPPLIED INCLUDE

- Inlet group complete with strainer, pressure-reducing valve, check valve, expansion relief valve and balanced cold connection
- Incoloy 3kW immersion heater(s)
- Port zone valve (except Direct models)
- Expansion vessel complete with flexible connection hose and hanging bracket



Available in Indirect, Twin Coil, Triple Coil, Direct and Eco Direct models



Volumes from 90 to 300 litres



Duplex stainless steel construction



316 stainless fittings and white leathergrain casing



High performance rigid coils

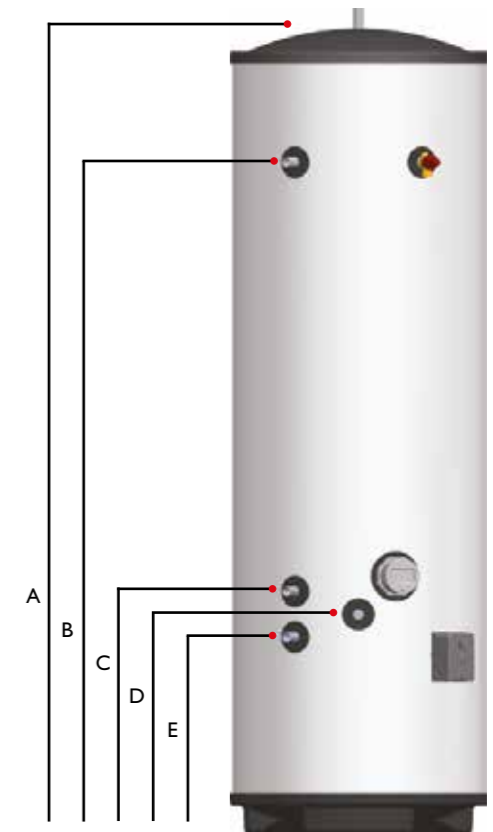
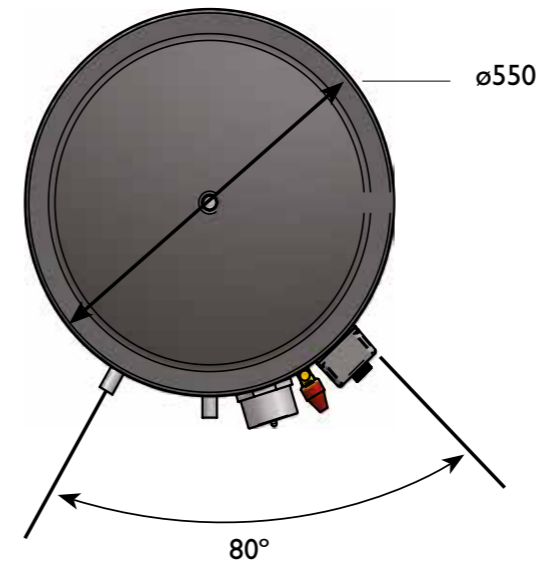

INDIRECT CYLINDER						
	IN120UV	IN180UV	IN180UV	IN210UV	IN250UV	IN300UV
<b>DIMENSIONS</b>						
(A) Height (mm)	952	1142	1327	1517	1767	2077
(B) Secondary return connection (mm)	-	-	-	1223	1473	1783
(C) Primary coil upper connection (mm)	462	462	532	532	532	532
(D) Cold inlet connection (mm)	412	412	482	482	482	482
(E) Primary coil lower connection (mm)	362	362	432	432	432	432
<b>OPERATING DATA</b>						
Cold water capacity (litres)	120	150	180	210	250	300
Weight when full (kg)	140	180	210	250	290	350
Standing heat loss (kWh/24h)	1.15	1.31	1.4	1.66	1.92	2.07
<b>PERFORMANCE</b>						
Primary coil rating @ 15L/min (kW)	17.5	17.2	21.3	19.9	22.4	20.4
Heat up time (EN12897) (mins)	19	25	25	31	34	41
ERP RATING	A	B	B	B	C	C

## TWIN COIL CYLINDER

Our Twin Coil models have all the features and benefits of the Indirect models but come with an additional coil for use with a renewable heat source, or an additional boiler. The models feature large dedicated renewable volumes, making them suitable for use with solar thermal systems in line with the recommendations in the Domestic Building Services Compliance Guide 2010.

The renewable coil (the lower of the two coils) has a large surface area to maximise the use of available low grade heat from a renewable resource. The cylinder thermostats for both coils are factory-fitted and an immersion heater is supplied for back-up. All Twin Coil models feature a dedicated 22mm connection for use with a secondary return (pumped circulation).

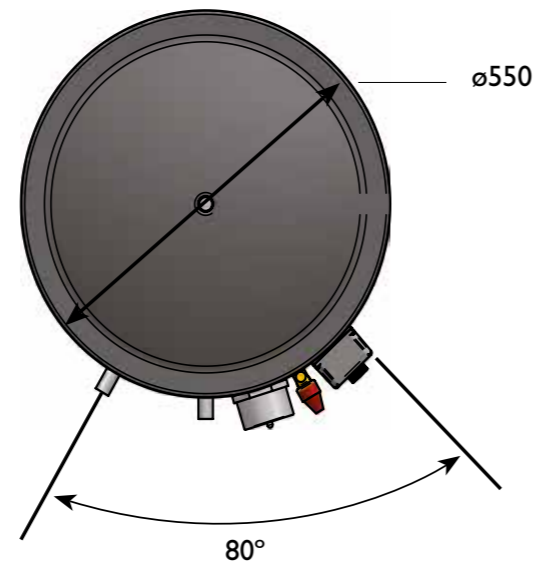

TWIN COIL				
	TW180UV	TW210UV	TW250UV	TW300UV
<b>DIMENSIONS</b>				
(A) Height (mm)	1327	1517	1767	2077
(B) Secondary return connection (mm)	-	1223	1473	1783
(C) Primary coil upper connection (mm)	973	1078	1078	1388
(D) Primary coil lower connection (mm)	873	978	978	1288
(E) Renewable coil upper connection (mm)	532	532	532	532
(F) Cold inlet connection (mm)	482	482	482	482
(G) Renewable coil lower connection (mm)	432	432	432	432
<b>OPERATING DATA</b>				
Cold water capacity (litres)	180	210	250	300
Weight when full (kg)	210	250	290	350
Standing heat loss (kWh/24h)	1.4	1.66	1.92	2.07
Dedicated renewable volume (litres)	70	105	105	155
<b>PERFORMANCE</b>				
Primary coil rating @ 15L/min (kW)	20.7	21.3	20.2	21
Renewable coil rating @ 15L/min (kW)	20.7	22.3	22	20.7
Primary heat up time (EN12897) (mins)	16	16	23	22
<b>ERP RATING</b>				
	B	B	C	C

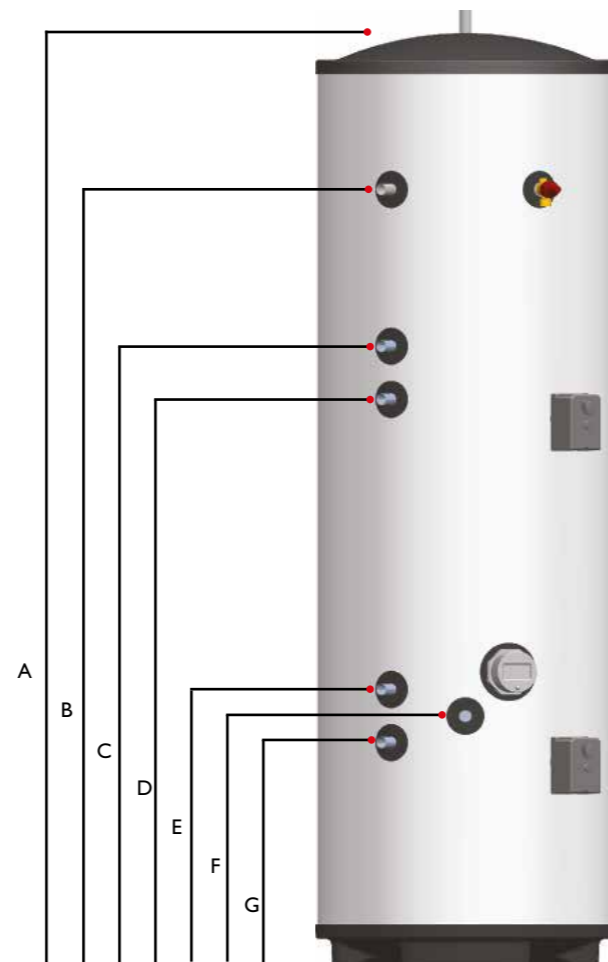

## TRIPLE COIL CYLINDER

Similar in specification to the Twin Coil models our Triple Coil cylinders feature a total of three heat exchanger coils – two 1" (28mm coils heating the upper section and a 22mm renewable coil at the bottom).

This flexibility means that, for example, the cylinder might be heated by a solar thermal system via the renewable coil, a wood pellet boiler supplying the primary coil and a back-up oil or gas boiler on the tertiary coil.

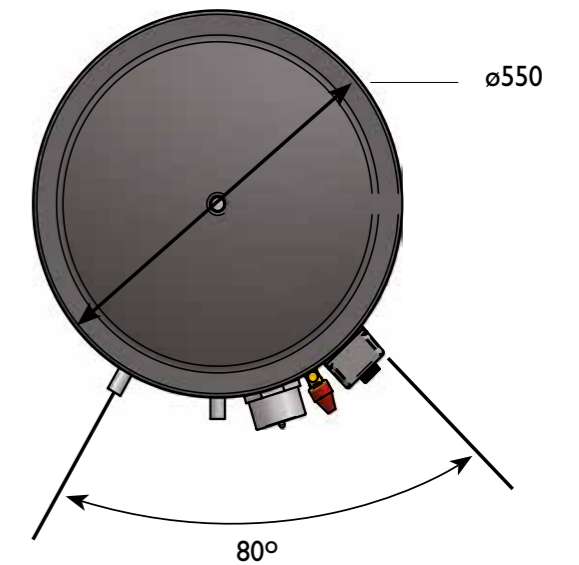

TRIPLE COIL		
	TR250UV	TR250UV
<b>DIMENSIONS</b>		
(A) Height (mm)	1767	2077
(B) Secondary return connection (mm)	1473	1783
(C) Tertiary coil upper connection (mm)	1403	1683
(D) Primary coil upper connection (mm)	1363	1643
(E) Tertiary coil lower connection (mm)	564	844
(F) Primary coil lower connection (mm)	524	804
(G) Renewable coil upper connection (mm)	462	532
(H) Cold inlet connection (mm)	412	482
(I) Renewable coil lower connection (mm)	362	432
<b>OPERATING DATA</b>		
Cold water capacity (litres)	248	298
Weight when full (kg)	290	350
Standing heat loss (kWh/24h)	1.92	2.07
Dedicated renewable volume (litres)	70	115
<b>PERFORMANCE</b>		
Primary coil rating @ 15L/min (kW)	18.2	19.2
Renewable coil rating @ 15L/min (kW)	20	20.9
Tertiary coil rating @ 15L/min (kW)	18.9	20.1
Primary heat up time (EN12897) (mins)	28	27
<b>ERP RATING</b>		
	C	C

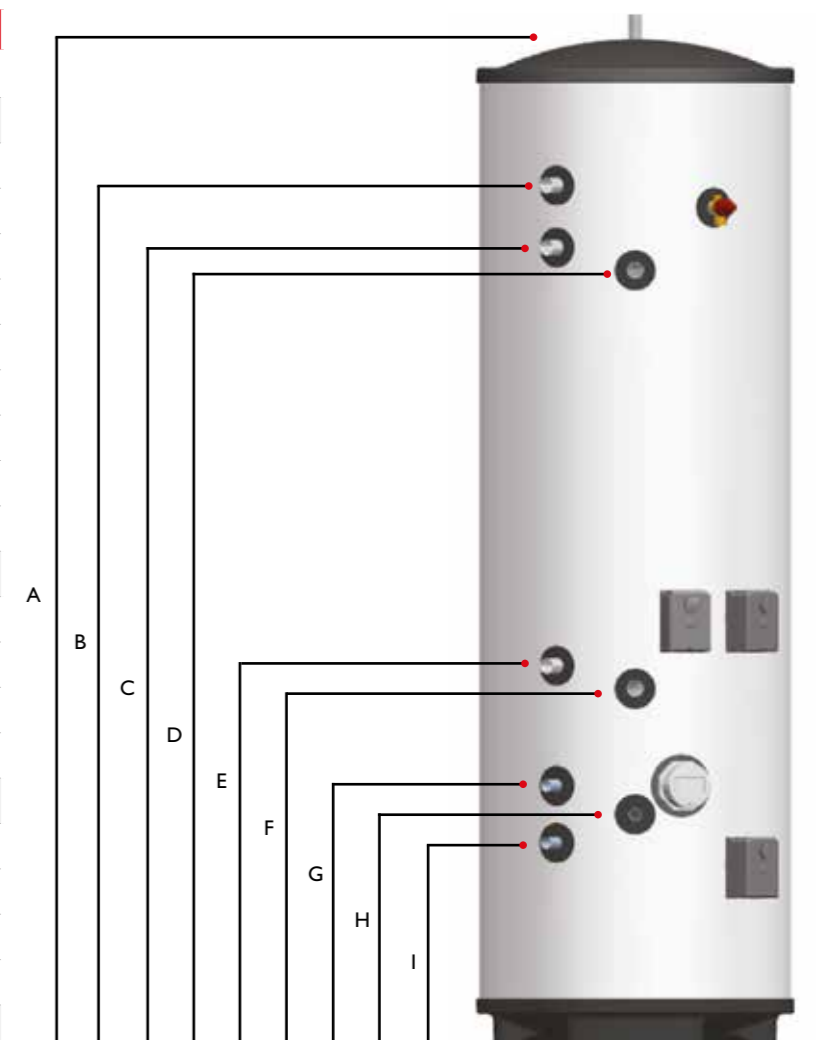



## ECO DIRECT CYLINDER

The Eco Direct is the Twin Coil equivalent for electric hot water installations. It features two immersion heaters intended for use in the same manner as those of a Direct cylinder, but also has an indirectly heated coil for use with a renewable resource, such as a solar thermal system.

The models feature dedicated renewable volumes and large surface area coils to maximise the use of available low grade heat from a renewable resource. By combining the use of renewable energy with the Economy 7 tariff, the Eco Direct models offer improved affordability where the use of fossil fuels is impractical and unavailable.

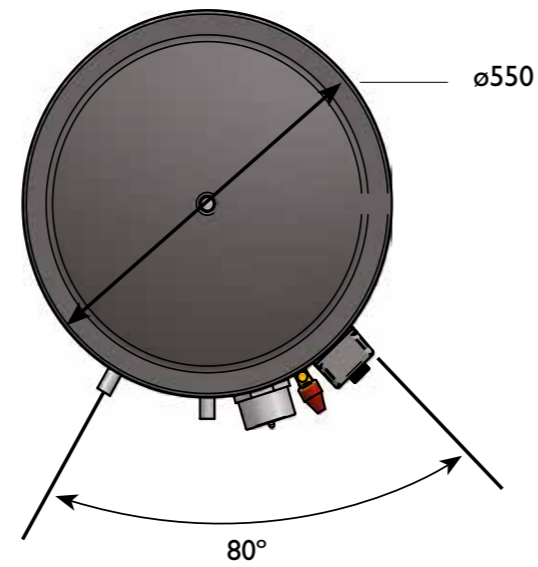

### ECO DIRECT CYLINDER

	ED180UV	ED210UV	ED250UV	ED300UV
<b>DIMENSIONS</b>				
(A) Height (mm)	1327	1517	1767	2077
(B) Secondary return connection (mm)	-	1223	1473	1783
(C) Upper Immersion (mm)	891	1078	1230	1540
(D) Lower Immersion (mm)	596	752	752	1062
(E) Renewable coil upper connection (mm)	532	532	532	532
(F) Cold inlet connection (mm)	482	482	482	482
(G) Renewable coil lower connection (mm)	432	432	432	432
<b>OPERATING DATA</b>				
Cold water capacity (litres)	180	210	250	300
Weight when full (kg)	210	250	290	350
Standing heat loss (kWh/24h)	1.4	1.66	1.92	2.07
Dedicated renewable volume (litres)	65	90	110	145
<b>PERFORMANCE</b>				
Renewable coil rating @ 15L/min (kW)	21.4	19.9	22.2	20.4
Heat up time by lower immersion (mins)	127	138	184	188
Heat up time by upper immersion (mins)	68	71	90	89
<b>ERP RATING</b>				
	B	B	C	C

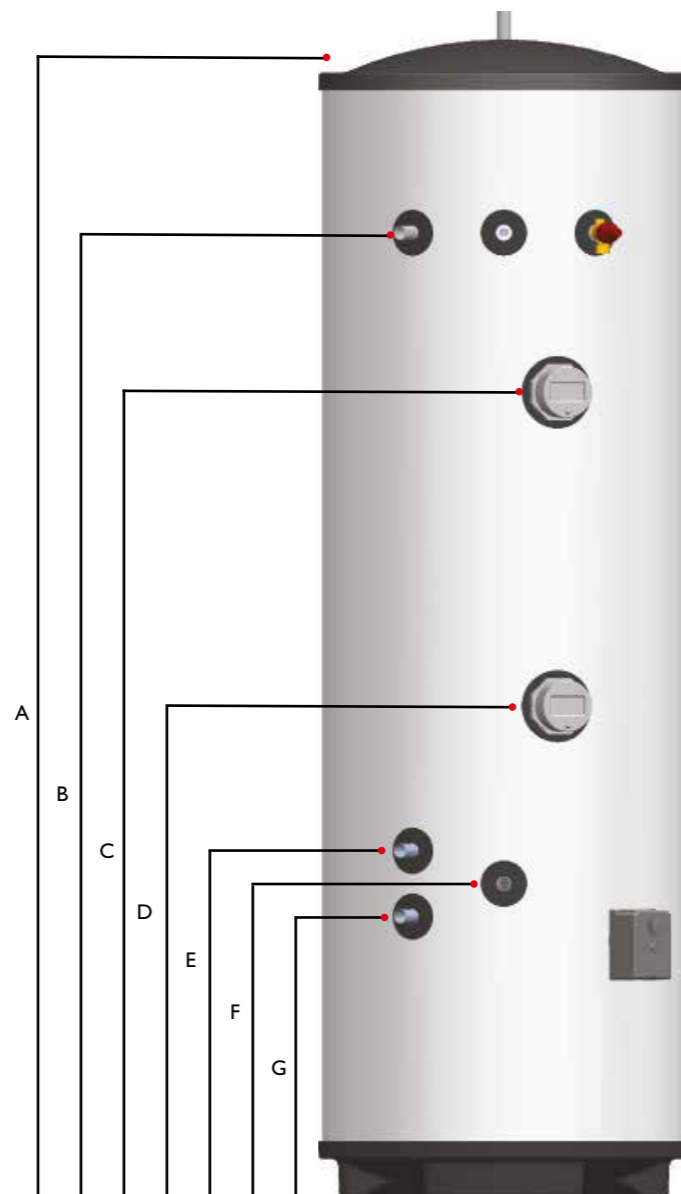

## DIRECT CYLINDER

The electrically heated Direct cylinders are designed for instances where the use of fossil fuels is impractical or unavailable.

Featuring two immersion heaters\*, one heating the entire cylinder volume and the other heating a boost volume at the top, the cylinders are able to make use of the Economy 7 tariff in order to minimise the cost of hot water.

If used in this way, the cylinder should be sized to provide the complete anticipated daily hot water use, thereby reducing the use of the boost element which runs on the more expensive standard tariff.

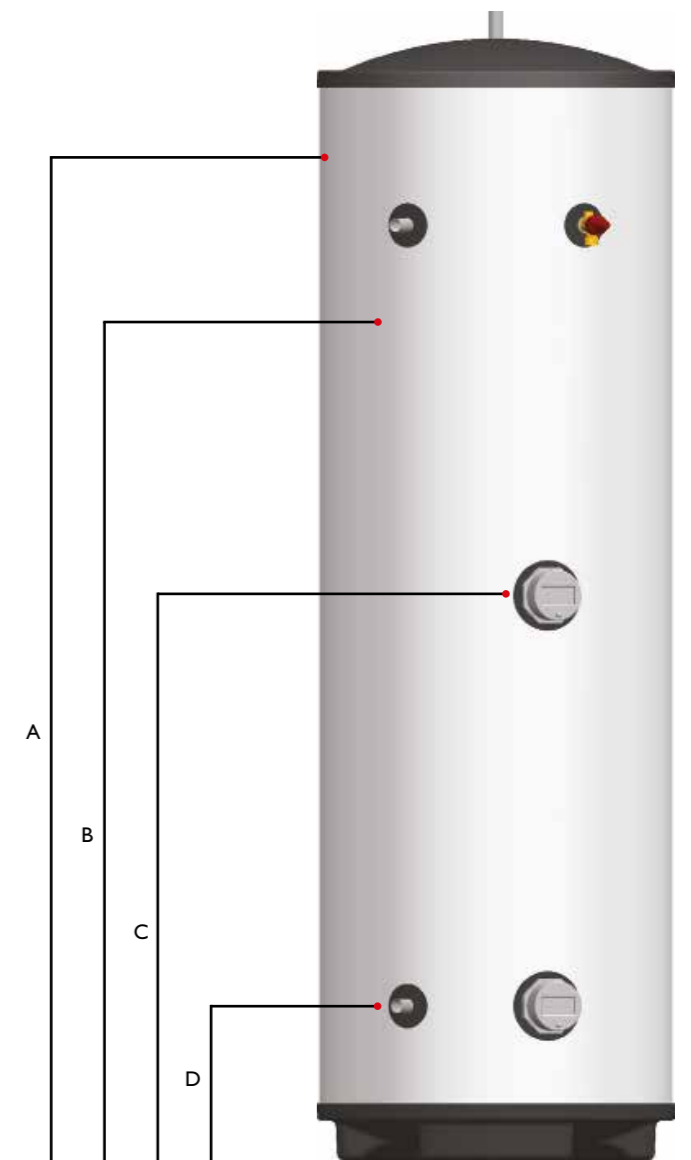
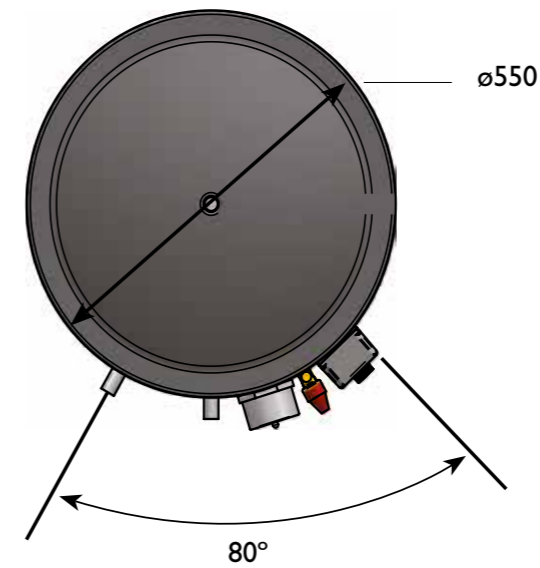

### DIRECT CYLINDER

	DI90UV	DI120UV	DI150UV	DI180UV	DI210UV	DI250UV	DI300UV
<b>DIMENSIONS</b>							
(A) Height (mm)	767	952	1142	1327	1517	1767	2077
(B) Secondary return connection (mm)	-	-	-	-	1223	1473	1783
(C) Primary coil upper connection (mm)	-	482	577	670	765	890	1045
(D) Cold inlet connection (mm)	243	243	243	243	243	243	243
<b>OPERATING DATA</b>							
Cold water capacity (litres)	90	120	150	180	210	250	300
Weight when full (kg)	110	140	180	210	250	290	350
Standing heat loss (kWh/24h)	0.92	1.15	1.31	1.4	1.66	1.92	2.07
<b>PERFORMANCE</b>							
Heat up time by lower immersion (mins)	89	121	154	198	237	287	345
Heat up time by upper immersion (mins)	n/a	73	93	113	131	156	189



## RENEWABLE ENERGY

High-efficiency, low emission appliances with a range of outputs to suit any installation.

AIR SOURCE HEAT PUMPS

GROUND SOURCE HEAT PUMPS

BIOMASS WOOD PELLET BOILER





## AIR SOURCE HEAT PUMPS

Our air source heat pump system harnesses natural heat energy from the air by blowing it through a highly finned evaporator coil. The heat pump then increases the temperature and the heat is used to provide home heating or hot water.

### Why Air Source?

**CHEAPEST FORM OF HOME HEATING**  
Our Air Source has a high efficiency of up to 555%. A heat pump can keep your home at a constant ambient temperature 24/7 for less cost due to lower flow temperatures.

**ENVIRONMENTALLY FRIENDLY**  
No harmful emissions to the environment.

**LOW MAINTENANCE**  
A yearly system check is recommended by your installer or qualified person. This will involve cleaning filters and checking system pressures to ensure the optimum performance of your heatpump.

**55°C HOT WATER**

**ONE ENERGY BILL**  
Just one electric bill for the whole dwelling, which includes lighting, appliances, heating and hot water.

**QUIET OPERATION**  
When running, the heat pump has a sound operation of 54dBa at 1m.

## A NEW NAME IN EFFICIENCY

From the outset of designing our heat pump it was conceived to be one of the most efficient appliances in its class.

Independent tests have shown its efficiency to be up to 555% at A7W35. This means that for every 1kW of electricity consumed 5.55kW of heat is produced. Under the new energy efficiency labelling the Warmflow Air source heat pump will have a Seasonal Coefficient of Performance (SCoP) rating of A++.

### How do we achieve such a high efficiency?

Unlike most other heat pumps which produce heat at a fixed output, our heat pump makes use of the latest variable speed compressor technology to produce heat at the rate you need. This gives the heat pump a wide output range and it automatically modulates within this range depending on your heat demands. To optimise the efficiency of the appliance it is equipped with the latest EC motor variable speed circulating pump, which matches its speed to the hydraulic resistance and the heat demand of the system.

For ease of installation, pumps and sealed heating system components including a pressure relief valve are conveniently housed within the heat pump casing. This speeds up installation and minimises wiring and plumbing needed on site. The unit also has an inbuilt monitoring system, which monitors flow temperature, flow rates and system temperatures for easy commissioning. A dedicated wiring centre greatly simplifies connection to external wiring and sensors making this heat pump very easy to install and service.

### KEY FEATURES

- **Variable speed-inverter driven compressor**  
Low noise, high efficiency Mitsubishi Rotary compressor; the heart of the system.
- **User-friendly touchscreen interface**  
Covering all aspects of heat pump and system control; the brain of the system.
- **Variable speed, high efficiency pump**  
Fully integrated, variable speed, high efficiency pump for the heating circuit modulates flow to match heating demand and overcome hydraulic resistance whilst maintaining peak efficiency.
- **Electronic controlled expansion valves**  
Optimising system efficiency by allowing the heat pump to run at a range of flow temperatures and capacities.
- **High Flow heat exchangers with large surface area**  
Maximising the heat supplied to the property whilst maintaining high flow rates for efficient operation.
- Designed to run from a standard single-phase domestic electricity supply.
- Flow temperature up to 55°C means domestic hot water (DHW) can be produced without the need for additional heat sources.
- Filters and flexi hoses as standard.



### SPECIFICATIONS

MODEL	AS01	AS02	AS03
Output	2~6kW	3~11kW	5~17kW
Width (mm)	1055	980	990
Depth (mm)	490	465	440
Height (mm)	790	910	1315
Pump	WILO RS15/6	GRUNDFOS UPMXL	GRUNDFOS CM3



## GROUND SOURCE HEAT PUMPS

Our ground source heat pump system harnesses natural heat energy stored in the ground by pumping brine through it. The heat pump then increases the temperature and the heat is used to provide home heating or hot water.

### Why Ground Source?

**CHEAPEST FORM OF HOME HEATING**  
Our Ground Source has a high efficiency of 508%. A heat pump can keep your home at a constant ambient temperature 24/7 for less than the cost of running with fossil fuels due to lower flow temperatures.

**ENVIRONMENTALLY FRIENDLY**  
No harmful emissions to the environment.

**LOW MAINTENANCE**  
A yearly system check is recommended by your installer or qualified person. This will involve cleaning filters and checking system pressures to ensure the optimum performance of your heat pump.

**60°C HOT WATER**

**ONE ENERGY BILL**  
Just one electric bill for the whole dwelling, which includes lighting, appliances, heating and hot water.

**QUIET OPERATION**  
When running, the heat pump has a sound operation of 55dBa at 1m.

## A NEW NAME IN EFFICIENCY

From the outset of designing our heat pump it was conceived to be one of the most efficient appliances in its class.

Independent tests have shown its efficiency to be 508% at B0W35. This means that for every 1kW of electricity consumed 5.08kW of heat are produced. Under the new energy efficiency labelling the Warmflow Ground source heat pump will have a Seasonal Coefficient of Performance (SCoP) rating of A+++

### How do we get such a high efficiency?

Unlike most other heat pumps which produce heat at a fixed output, our heat pump makes use of the latest variable speed compressor technology to produce heat at the rate you need. This gives the heat pump a wide output range and it automatically modulates within this range depending on your heat demands. To optimise the efficiency of the appliance it is equipped with the latest EC motor variable speed circulating pumps, which matches its speed to the hydraulic resistance and the heat demand of the system and extraction rate of the ground loop.

For ease of installation all pumps and sealed heating system components including a 12l expansion vessel are conveniently housed within the heat pump casing. This speeds up installation and minimises wiring and plumbing needed on site. The unit also has an inbuilt monitoring system, which monitors flow temperature, flow rates and system temperatures for easy commissioning.

A dedicated wiring centre greatly simplifies connection to external wiring and sensors making this heat pump very installer and service friendly.

### SPECIFICATIONS

MODEL	GS08	GS16
Output	3~8kW	4.5~18kW
Width (mm)	590	
Depth (mm)	660	
Height (mm)	885	
Brine Pump	UPM GEO 25-85	UPMXL GEO 25-125
Heating Pump	UPM2 25-75	UPML 25-105
Sealed System	Yes	

\*Based on system volumes up to 150L





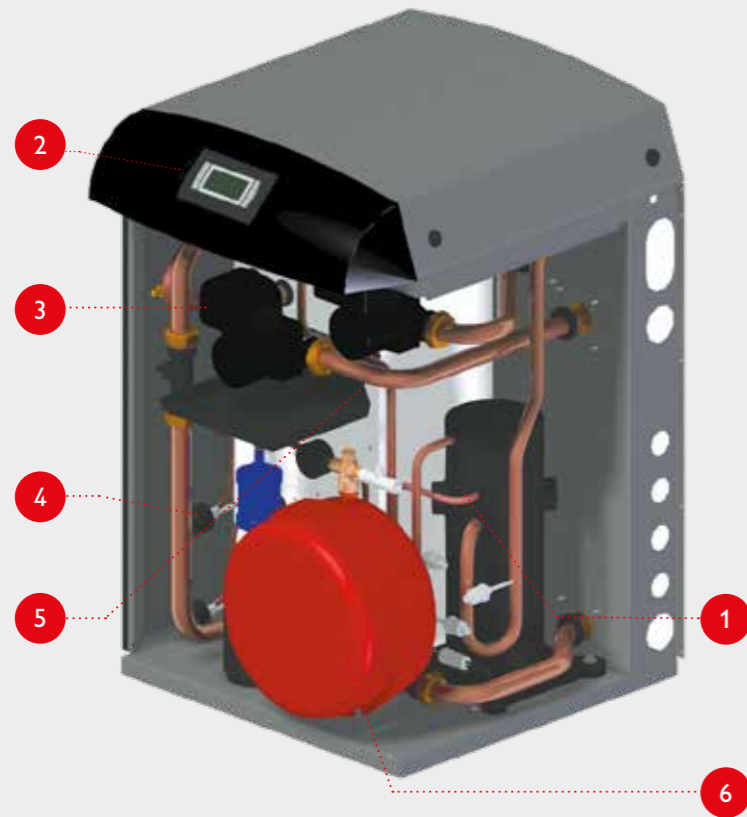

## Ground Source Key Points

### 1. Variable speed inverter driven compressor

Low noise, high efficiency scroll compressor; the heart of the system.

### 2. User-friendly interface

Covering all aspects of heat pump and system control; the brain of the system.

### 3. Variable speed, high efficiency pumps

Fully integrated, variable speed high efficiency pumps for brine and heating circuits, modulate flow to match heating demand and overcome hydraulic resistance whilst maintaining peak efficiency.

### 4. Electronic controlled expansion valves

Optimising system efficiency by allowing the heat pump to run at a range of flow temperatures and capacities.

### 5. Plate heat exchangers with large surface area

Maximising the heat extracted from the ground and the heat supplied to the property.

### 6. Complete sealed system kit

12l expansion vessel, filling loop and 3-bar safety valve for the heating circuit.\*

## GOOD TO KNOW

Designed to run from a standard single-phase domestic electricity supply.

Flow temperature up to 65°C means domestic hot water (DHW) can be produced without the need for additional heat sources.

Filters and flexi hoses as standard.



Warmflow 'Red' Brine Solution: an ethylene glycol-based, high-efficiency, non-toxic heat transfer fluid. Also features anti-freeze function with BS6580 corrosion, scale and biological inhibitors.

\*Based on system volumes up to 150L

## BIOMASS WOOD PELLET BOILERS

### Why choose wood pellet boilers?



#### CARBON NEUTRAL

Wood pellets are a carbon neutral, renewable biomass energy fuel. The CO<sub>2</sub> released when burning wood is re-absorbed by the amount of new trees that are planted.



#### WELL-ESTABLISHED

The use of wood pellets for domestic and commercial use has been well established in Europe for the last 25 years.



#### QUALITY

The Warmflow biomass boiler has been designed to run on ENplus A1 pellets only, the highest kitemark of quality in the industry. The ENplus quality certification replaces numerous national standards and certifications with one uniform system based on the EN 14961-2 standard for wood pellets.



#### COST-EFFECTIVE

Wood pellet boiler equipment is cost-effective to both install and operate and has significantly lower maintenance and capital expenditure costs compared to wood chip boilers. Wood pellets are manufactured from a widely available feedstock typically resulting in less price volatility than with fossil fuels.

The ENplus standard covers the whole chain for wood pellets - from production to delivery ensuring high quality as well as transparency. All ENplus A1 pellets are derived from 100% virgin wood fibre with no additives ensuring that not only do the wood pellets burn beautifully, but also that the process is exceptionally clean giving low emissions and trouble-free heating with high energy value.

Using non ENplusA1 pellets will invalidate your warranty, reduce efficiency and increase cleaning and servicing frequency.

## USER FRIENDLY CONTROL PANEL

WS18 / WP18	
Output	4~18kW; Modulating
Flue Options	Black powder coated conventional flue system
Conventional flue size (mm)	100
EN303-5 Efficiency class	Class 5
Height (mm)	1135
Depth (mm)	1170
Width (mm)	650
Service access	Front, Top & Sides
Circulating pump	Factory-fitted UPM 25-75



**WARMFLOW**



## KEY FEATURES

At Warmflow we pride ourselves on our innovation and customer focus so we designed our biomass boiler to meet all possible performance demands.



## KEY FEATURES CONTINUED

- Can be fitted in a garage, an outbuilding or outdoors.
- 60 litre boiler capacity eliminates the need for a buffer tank in the majority of installations.
- Only uses ENPlus A1 pellets.
- High durable, black powder-coated, push-fit flue with options.
- Ceramic ignitor with intelligent software to give quick and reliable ignition.
- Fits through a doorway and takes up similar footprint to a slimline oil tank, saving you valuable space.
- Smart induced draught fan technology with lambda control continually adjusts to give you the best efficiency all the time.
- Auto restart after power cuts – no manual intervention needed so you won't be waking up to cold water and a cold house after an overnight power cut while you were sleeping.
- User-friendly, menu-based controller guides you through every step. Future-proofed to allow new software developments such as smart phone technology to be uploaded at routine services.
- Installer friendly – simplified wiring.
- Simple flow and return plumbing.
- Optional patent pending installation buggy kit, making it easy to move into place.



Easy installation in a matter of hours



- DEFRA exempt
- Approved by MCS
- HETAS approved appliance scheme



Eligible for government grants



Exempt from the Clean Air Act



## WOOD PELLET FLUE SYSTEM & FLUE KIT ACCESSORIES

The 'Easy-Fit' twin wall metal flue system has been specifically designed for use on biomass appliances. The inner wall is manufactured from high grade aluminium with the outer wall finished in a weather-resistant and durable black powder coating.

Utilising a push-fit system ensures ease of use and quick installation. The system is also suitable for internal use and can be used in conjunction with our Roof Flashings kits as required.

### Pitched Roof Flashing

4348

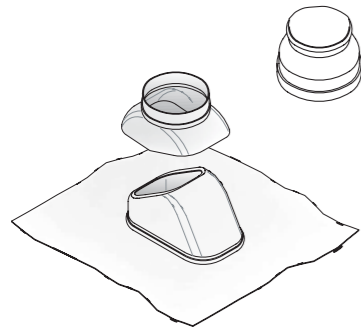

### Flat Roof Flashing

4349

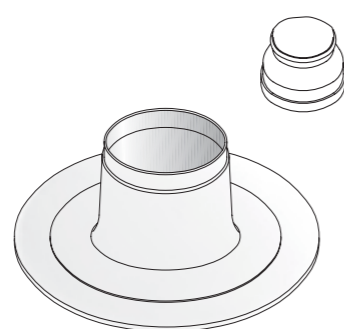

### Vertical Flue Kit 080/100

4142

Included with every WP18 is:

- 500mm Extension
- Flue Terminal (584mm)

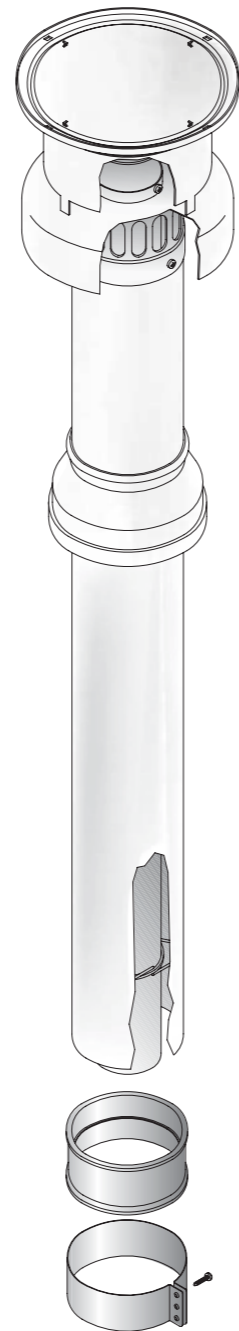

### 45° Bend

4187

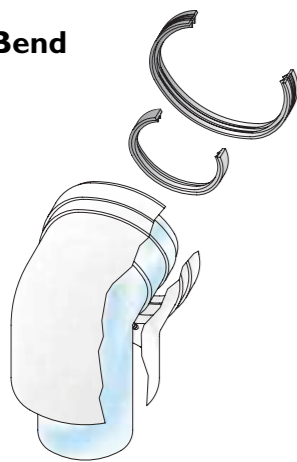

### Wall Brackets

- Supporting Collar for pipes (4189 standard)
- Supporting Collar for pipes (4347 extended)

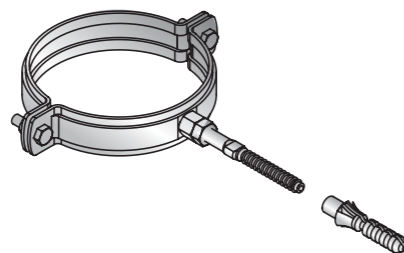

### Concentric Extension

- 4181 - 500mm
- 4188 - 1000mm

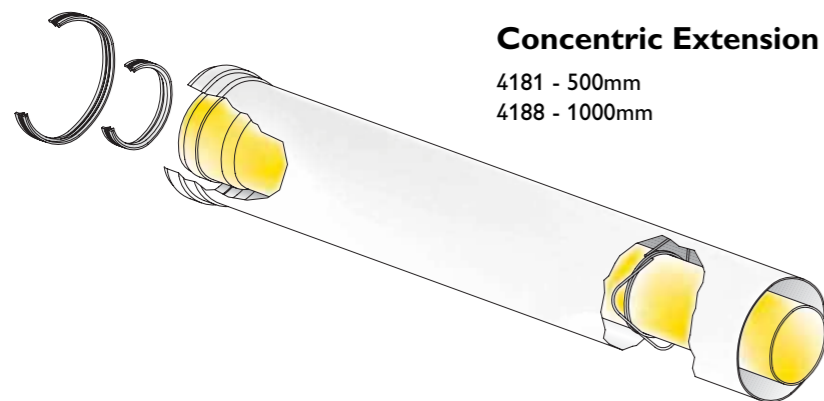

## WARMFLOW CUSTOMER SERVICE

Total peace of mind with our dedicated Customer Service team

Our dedicated and knowledgeable customer support team is on hand to provide expert support before, during and after-sales, to ensure that your queries are addressed in a timely fashion. All Warmflow products must be registered in line with terms and conditions otherwise warranty may be invalid.

\*Full details of terms and conditions of warranty for your Warmflow product are available at [www.warmflow.co.uk](http://www.warmflow.co.uk).



INNOVATIVE | RELIABLE | EFFICIENT

## WARM AIR HEATING SYSTEMS

Ideal for:

Garages

Warehouses

Commercial & Domestic Workshops



For more information please visit [www.warmflow.co.uk](http://www.warmflow.co.uk)  
contact [sales@warmflow.co.uk](mailto:sales@warmflow.co.uk) or call 028 9262 1515



# SIGN UP TO OUR INSTALLER SCHEME. IT'S AS EASY AS 1, 2, 3

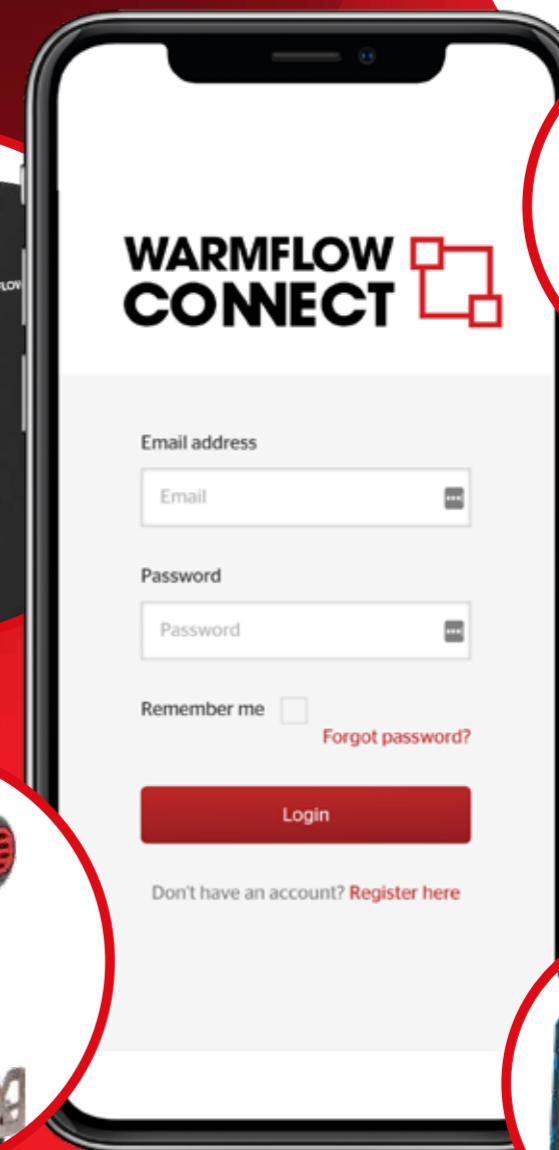

## Are you a Warmflow installer, Why not sign up to our Installer Scheme?

The Warmflow Installer Scheme will allow you to register all of your Warmflow products, purchase extended warranties and claim rewards for every purchase you make. Points mean rewards with Warmflow. Sign up online today at the Warmflow Connect platform [connect.warmflow.co.uk](http://connect.warmflow.co.uk)  
Email [connect@warmflow.co.uk](mailto:connect@warmflow.co.uk) or contact your Warmflow sales representative.